

Bioflon

SMOOTHBORE PTFE LINED HOSE

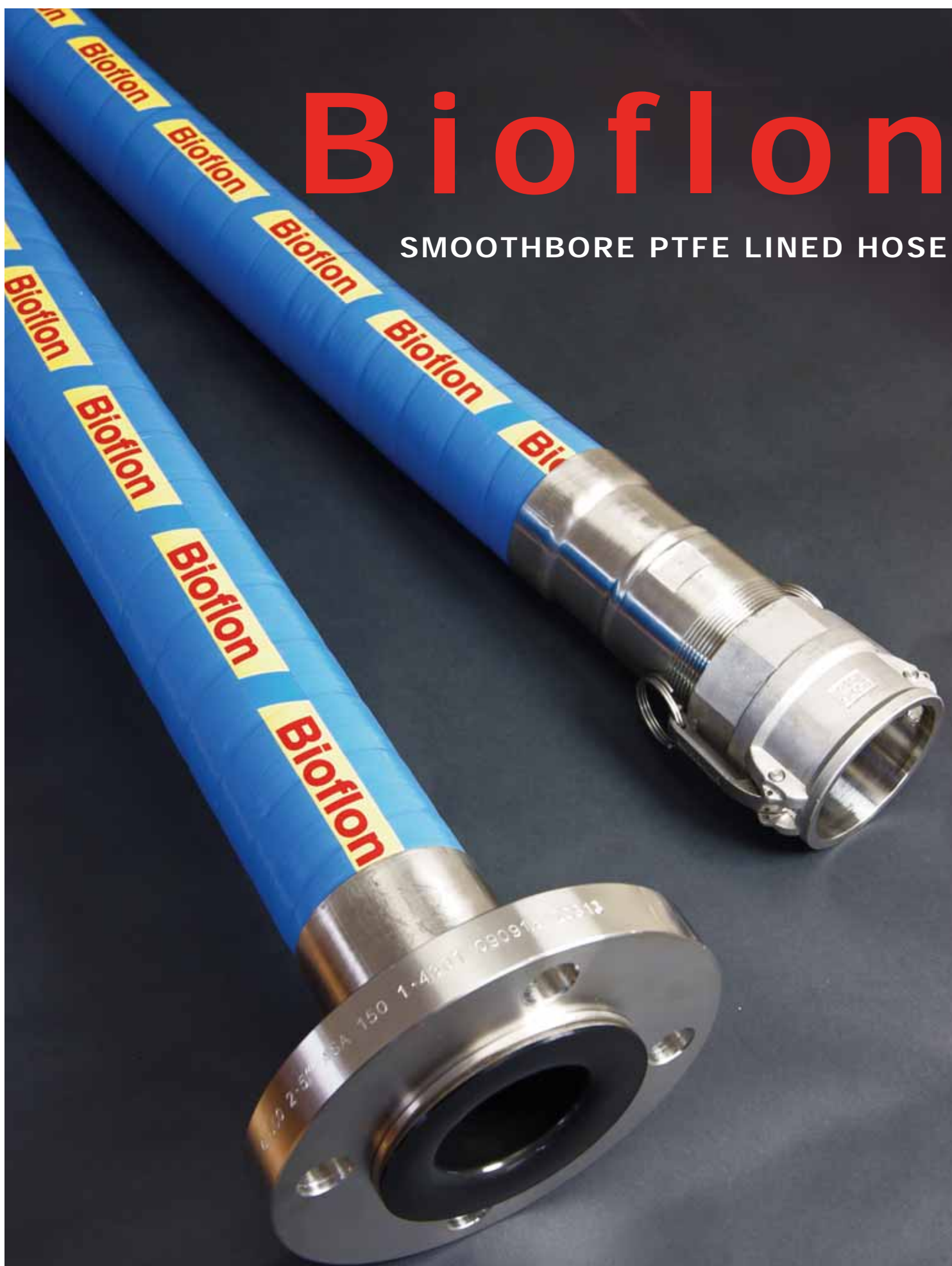

For Chemical Process Fluids Applications

CONTENTS

Front Cover Page 1

Contents Page 2

PTFE - The Optimum Choice For Hose Linings Page 3

Aflex Hose and Bioflon Page 4

Bioflon Hose Description Page 5

Bioflon Hose Grades, Specifications and Properties Page 6

Bioflon Integral PTFE Lined Flange Fittings Page 7

Bioflon Non-Lined Swivel Flange Fittings,
and Bioflon NPT and BSPT Fixed Male Fittings Page 8

Bioflon Special Usage Conditions Page 9

Bioflon Quality Assurance, Certification
and Approvals and Hose Testing Page 10

Hose Configuration & Length Calculations:
- for Bend Radius Page 11
- for Abrasion & Torque Page 12
- for Length Calculations Page 13

Conditions of Sale Page 14

PTFE - THE OPTIMUM CHOICE FOR HOSE LININGS

PTFE, or Polytetrafluoroethylene, comprises long-chain molecules of carbon atoms, each linked to two fluorine atoms.

The fluorine atoms provide a helical spiral which surrounds the carbon chain and protects it.

It is this structure which creates the unique properties for which PTFE is well-known.

EXCELLENT CHEMICAL RESISTANCE

PTFE is renowned as the most chemically resistant material known. Only a very few, very unusual substances and conditions can affect it, like fluorine gas at high temperature and pressure and liquid, boiling sodium metal.

PTFE lined hoses can therefore be used for a wider variety of chemicals than any other hose type, making it the ideal choice for very corrosive chemical applications and multi-product applications.

NON-STICK SURFACE

The use of PTFE as a surface for cookware products has demonstrated to the world how easily cleanable PTFE surfaces are.

This means that PTFE lined hoses can be purged 100% clean more quickly, easily and reliably than any other type of hose.

EXCELLENT TEMPERATURE RANGE

The cookware application also demonstrates another of PTFE's many attributes – temperature resistance. PTFE itself can be used as a hose liner at temperatures from -150°C up to $+260^{\circ}\text{C}$, dependent upon the hose design and the application conditions.

This is the widest temperature range of any rubber or plastic hose lining material.

HOSE DESIGN

The only issue with PTFE as a hose lining material is the best way it can be integrated in to the hose design. This is where Aflex Hose have a proven record of success over the last 30 years.

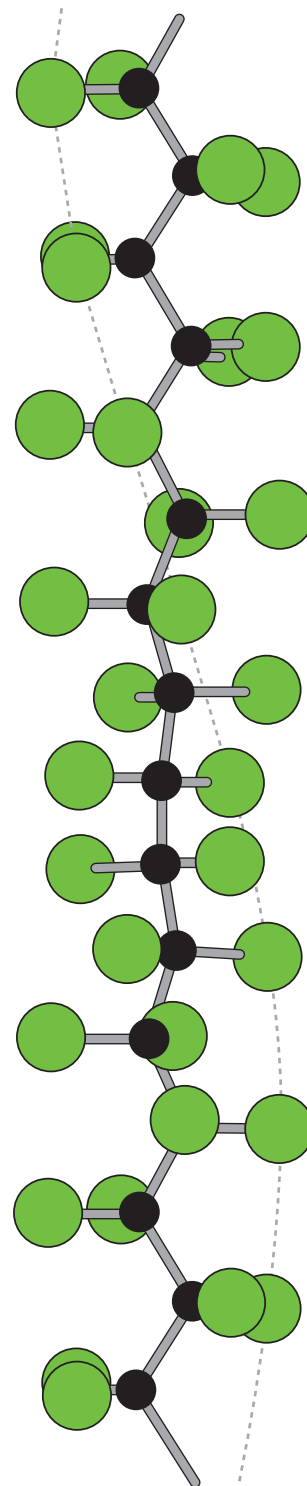

Section from a PTFE Molecule, 16 Angstrom Units long.



Fluorine Atom



Carbon Atom

AFLEX HOSE - THE WORLD'S LEADING MANUFACTURER OF PTFE FLEXIBLE HOSE



Aflex Hose, founded in 1973, pioneered the concept of PTFE lined flexible hose for the transfer of process fluids more than 35 years ago.

Corroflon convoluted, together with Bioflex and Corroline smooth bore PTFE hose and other types of PTFE hose, manufactured and supplied by Aflex, are used by major Chemical, Pharmaceutical and Food companies worldwide.

Over the years, hundreds of thousands of custom-built hoses have been designed and built to cope with the most difficult of operating conditions, and Aflex have continuously developed and expanded their product range having pioneered and introduced Antistatic hose, Polypropylene Braided hose, integral PTFE lined end fittings and many other innovations in response to customer demands.

The full range of PTFE lined hose products manufactured by Aflex Hose is available on the Aflex Hose website at: www.aflex-hose.com.

Aflex Hose and Bioflon

Aflex Hose first developed and marketed the Bioflon Hose Product Range in all sizes up to 3" in 1995. This product range was withdrawn in 2000, due to the introduction of Bioflex and Corroline, which have a smooth bore like Bioflon, but are much more flexible.

Bioflex and Corroline, however, are only available in bore sizes up to 2", and customers have called upon Aflex to also provide a smooth bore PTFE lined hose product to complement the Corroline Hose range in the larger bore sizes, 2½" and 3".

There are technical difficulties associated with extending the Corroline range up to 3" bore, and so it has been decided that Aflex should re-introduce 2½" and 3" bore Bioflon Hose in order to satisfy customer requirements.

So,

For Hose Bore Sizes from ¾" (10mm) up to 2" (50mm) → USE CORROLINE

For Hose Bore Sizes from 2½" (65mm) and 3" (80mm) → USE BIOFLON

Note: Unlike Corroline, Bioflon is only available with an EPDM blue rubber cover over a stainless steel wire braid. The rubber cover is hand wrapped, not extruded, so although it has a smooth surface finish, it is not as even as the extruded cover on Corroline hose.

Also, as indicated above, Bioflon is less flexible than Corroline hose. If good flexibility is a primary requirement, customers may want to consider the option of a 2" bore Corroline Hose, with special, larger 2½" or 3" end fittings attached.

BIOFLON HOSE DESCRIPTION

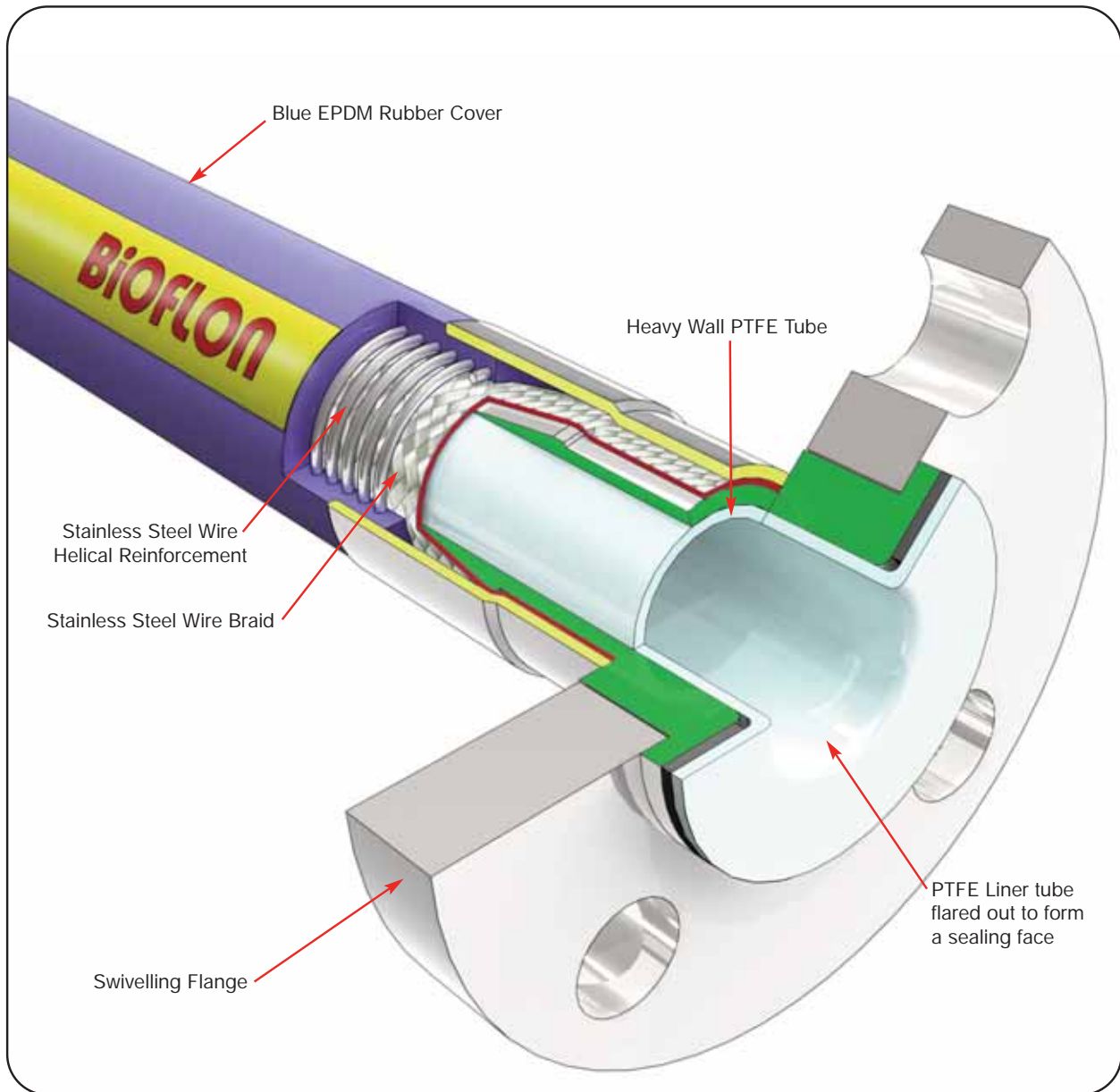

Construction

- Bioflon Hose includes a smooth bore, thick wall PTFE tube liner. Either Natural PTFE, Grade GP or Antistatic (Black) PTFE, Grade AS.
- A stainless steel wire braid is applied to the outside of the PTFE tube liner.
- A stainless steel reinforcement wire is helically wound over the wire braid.
- An abrasion resistant Blue EPDM Rubber Cover is hand-wrapped on the outside, which moulds around and conforms to the helical wire, holding the wire in place on the hose.

- Notes:**
- The helical wire provides "hoop strength" to the hose construction, reinforcing the hose against kinking and crushing forces.
 - No Glue is used in the hose construction to bond layers together, thus preventing any possible contamination of the process fluid.

BIOFLON HOSE GRADES, SPECIFICATIONS AND PROPERTIES

BIOFLON GRADE GP



PURPOSE

Bioflon GP is the 'General Purpose' grade, for use in all applications where fluids or gases are being conveyed which do not generate a risk of static charge development (see Bioflex Grade "AS").

MATERIALS & SPECIFICATIONS

Bioflon GP has a virgin PTFE liner, manufactured from hose grade PTFE which conforms to the requirements of: FDA 21 CFR 177.1550.

GP & AS GRADE APPROVALS

The full list of approvals and certifications are given on Page 10.

BIOFLON GRADE AS



PURPOSE

Bioflon AS is an essential requirement in applications where there is the risk of an electrostatic charge build-up on the inside surface of the PTFE tube which may then discharge through the tube wall. Media passing through which create such a risk are fluids which have a Conductance of less than 10^{-8} S/m (Siemens per Metre), or 10^4 pS/m such as fuels, solvents, freons, some WFI (ultra-pure "Water for Injection") and non-polar organics which are being transferred at a medium to high flow velocity.

All twin or multi phase media, and any non-mixing media, such as powder in air, or water droplets in steam, in gases or in oil, also colloidal fluids constitute a particular hazard for static charge generation, and always require grade AS.

If in doubt, consult Aflex Hose.

BIOFLON GP AND AS GRADES - SPECIFICATIONS & PROPERTIES

Nominal Hose Sizes		Actual Bore Size		Outside Diameter		Maximum Working Pressure		Minimum Bend Radius		Maximum Continuous Length	
in	mm	in	mm	in	mm	psi	bar	in	mm	Feet	Metres
2 1/2	65	2 3/8	60.0	3.07	78.0	300	20	31	800	32	10
3	80	2 7/8	73.0	3.80	96.5	230	16	39	1000	32	10

TEMPERATURE RANGE: -40°C to +140°C / -40°F to +284°F

VACUUM RESISTANCE: Dependent upon temperature and degree of flexing.

FLEXIBILITY AND KINK RESISTANCE: Comparable with other Smooth Bore PTFE/PFA/FEP lined hose products with a rubber cover.

FIRE RESISTANCE: Fire Resistant to BS5173 Section 103.13 Parts 6.2 and 6.3.

BIOFLON INTEGRAL PTFE LINED FLANGE FITTINGS

■ FLANGE SPECIFICATIONS

- ANSI B16.5 (also ASME B16.5) Class 150# and 300#
- *DIN PN10, PN16 and PN40
- JIS 10K
- Other Pressure Ratings and Flange Specifications are also available.

*DIN PN10, PN16 and PN40 Flanges all have the same dimensions, and so are fully interchangeable.

■ END FITTING MATERIALS

- Flanges in Grade 304 SS
- Flange Retainers in Grade 316L SS
- Ferrules, most in Grade 304 SS, some sizes in Grade 316 SS

■ PRESSURE RATINGS FOR FLANGE FITTINGS

- ANSI 150# = 230 ps (16 Bar) , ANSI 300# = 460 psi (32 Bar).
- DN PN10 = 145 psi (10 Bar), DN PN16 = 230 psi (16 Bar).

INTEGRAL PTFE LINED SWIVEL FLANGE FITTINGS

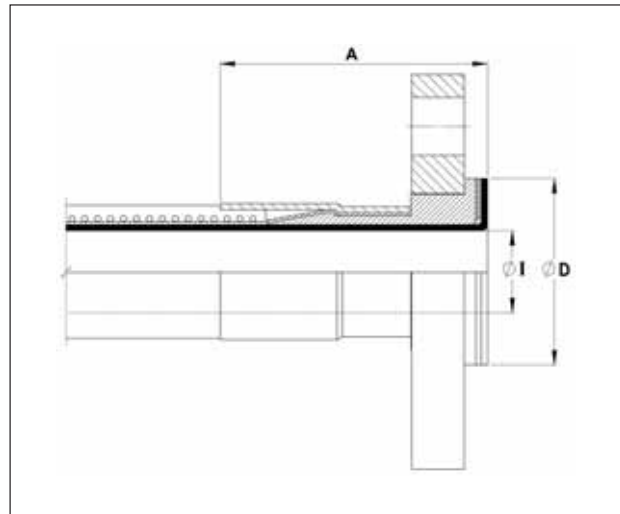
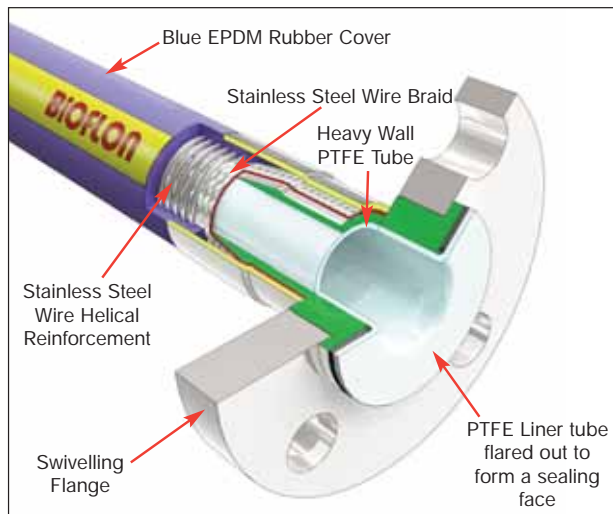

Nominal Hose Size		*Fitting Length A		Flared Diameter D				Fitting Inside Dia. and Hose Bore I	
				ANSI 150#		**DIN PN10/16/40			
in	mm	in	mm	in	mm	in	mm	in	mm
2 1/2	65	4.00	101	4.13	105	4.8	122	2 3/8	60.0
3	80	4.33	110	5.00	127	5.0	127	2 7/8	73.0

**The listed Flare Diameters are not all full size, due to limitations on PTFE flare diameters.

BIOFLON NON LINED SWIVEL FLANGE FITTINGS

■ FLANGE SPECIFICATION

- ANSI B16.5 (also ASME B16.5) Class 150# and 300#
- *DIN PN10, PN16 and PN40
- JIS 10K
- Other Pressure Ratings and Flange Specifications are also available.

*DIN PN10, PN16 and PN40 Flanges all have the same dimensions, and so are fully interchangeable.



■ END FITTING MATERIALS

- Flanges in Grade 304 SS
- Flange Retainers in Grade 316L SS
- Ferrules, most in Grade 304 SS, some sizes in Grade 316L SS

■ PRESSURE RATINGS

- ANSI 150# = 230 psi (16 Bar), ANSI 300# = 460 psi (32 Bar).
- DN PN10 = 145 psi (10 Bar), DN PN16 = 230 psi (16 Bar), DN PN40 = 580 psi (40 Bar).

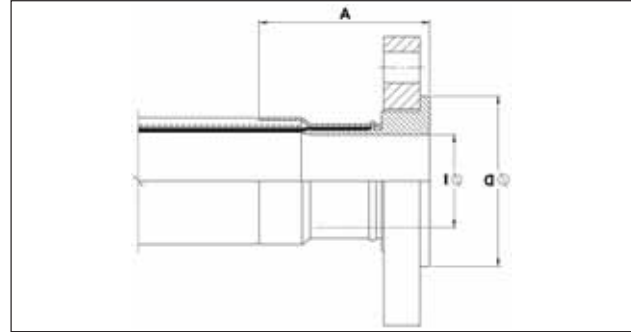

Nominal Hose Size		*Fitting Length A		Flared Diameter D				Fitting Inside Dia. and Hose Bore I	
				ANSI 150#		**DIN PN10/16/40			
in	mm	in	mm	in	mm	in	mm	in	mm
2 1/2	65.0	4.0	101	4.13	105	4.81	122	2 1/4	57.1
3	80.0	4.1	104	5.00	127	5.44	138	2 5/8	66.7

BIOFLON NPT AND BSPT FIXED MALE AND NPT FIXED FEMALE FITTINGS

■ End Fitting Specification

NPT Taper Threads to American National Standard Pipe Taper Thread design to ANSI B2.1.

BSPT Threads to British Standard Pipe Taper Thread design to BS21.

■ End Fitting Materials

- Fittings in Grade 304 SS
- Ferrules, most in Grade 304 SS, some sizes in Grade 316L SS
- Alternatives - Fittings in Zinc Plated Carbon Steel

Fixed Male NPT or BSPT

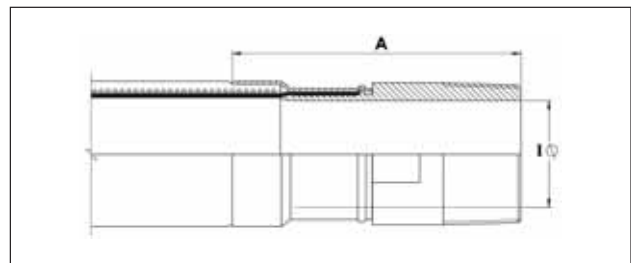

Nominal Hose Size		NPT or BSPT Thread Size	*Fitting Length A		Fitting Inside Diameter I	
in	mm	in	in	mm	in	mm
2 1/2	65.0	2 1/2	4.0	101	2 1/4	57.1
3	80.0	3	4.3	110	2 5/8	66.7

BIOFLON HOSE: SPECIAL USAGE CONDITIONS

■ CLEANING & STERILISING SYSTEMS - CIP, SIP AND AUTOCLAVE

CIP & SIP – PTFE liner tubes are chemically resistant to all CIP, SIP and Autoclave conditions. The primary consideration is whether the cleaning and purging cycle is likely to develop an electrostatic charge on the internal surface of the liner, in which case AS (Anti-Static) grade hose is required.

AS grade hose and Electrostatic charge generating systems are fully described in the hose liner section.

CIP systems using high electrical resistivity solvents like Toluene will require AS grade hose.

Another electrostatic generation problem arises when wet steam is used, or when the cleaning fluids or WFI are purged out of the line using nitrogen, compressed air or another gas, because droplets of liquid or water in the gas then generate a multi-phase condition until they are cleared out, which will generate a static charge, and so will require AS grade hose.

In static generating applications where AS grade hose is not acceptable due to the black PTFE liner, alternative solutions are available – please consult Aflex Hose for advice.

Autoclave – Autoclave sterilisation does not normally involve any high flow rates through the hose bore, so static generation is not a problem. Aflex hose grades GP and AS, with SS or HB braids are fully resistant to all autoclave conditions throughout the service life of the hose.

The rubber covered grades EPDM, (RC) and Silicone Rubber (RC, SI) are able to withstand at least 100 x 30 minute autoclave cycles at relatively high autoclave temperatures (121°C, 250°F or 135°C, 275°F). Consult Aflex Hose for more specific information.

■ PTFE HOSE-USE WITH ALKALI METALS, HALOGENS AND HALOGEN CONTAINING CHEMICALS

PTFE hose liners react chemically with Fluorine, Chlorine Trifluoride and molten Alkali Metals.

When PTFE lined hose is used to carry Chlorine or Bromine, either as gasses or fluids, they will diffuse into and through the PTFE liner wall thickness. Trace quantities will then combine with atmospheric moisture to corrode any braid/rubber outer coverings.

Heavily halogenated chemicals, like Hydrogen Fluoride, Hydrogen Chloride, Phosgene (Carbonyl Chloride) Carbon Tetrachloride and other organic chemicals with a high halogen content can also be absorbed and transmitted through the PTFE liner tube.

■ OTHER 'PENETRATING' FLUIDS AND GASES

Sulphur Trioxide, Methyl Methacrylate and Glacial Acetic Acid are some other chemicals which can be absorbed and transmitted through the PTFE liner tube wall.

Generally, however, as a hydrophobic (non-wetting) material, PTFE is very resistant to the absorption of chemicals. In some cases, PTFE has superior resistance to diffusion, for example to the diffusion of automotive fuels, in comparison with all other plastics and rubbers.

■ GAS/FLUID CYCLING

There are some applications where the fluid passing through the hose turns into a gas, then back into a fluid, then into a gas etc, in a cyclic sequence.

This is normally associated with changes in temperature and/or pressure. For complex reasons these conditions are extremely damaging to the hose liner, whatever material it is made from.

For example, hoses are sometimes used to pass steam, water, steam etc into rubber moulding presses, in order to heat the mould, then rapidly cool it before reheating in the next cycle. Hoses of all types fail rapidly in such an application and PTFE lined hoses are no exception.

Please contact Aflex Hose for further information if these conditions apply.

■ CONNECTING ASSEMBLIES FOR USE IN APPLICATIONS

The lengths of hose assemblies and their configuration in use when connected into the application must always be in accordance with the Hose Configuration information at the end of this product literature.

When being connected for use in applications, the end fittings on hose assemblies must be connected to correct mating parts in the correct way, using the correct tools, spanners, clamps, nuts and bolts etc. The connections must be sufficiently tightened to ensure that the joint is leak free but not be over tightened as this can damage the sealing surfaces, especially with PTFE lined and flared end fittings.

In applications involving the transfer through the hose of expensive or dangerous fluids or gases, the hoses and connections must be pressure tested in situ before being put in to service. This should be done with some harmless media to 1½ times the maximum working pressure of the hose assembly, as stated in the product literature.

If in doubt please contact Aflex Hose for advice.

■ SPECIAL APPLICATIONS

Aflex Hose PTFE lined hose products are not rated as suitable for use in the following, special applications:

All Radioactive Applications involving high energy radiation, including Gamma radiation (degrades PTFE)

All Medical Implantation Applications.

All Aerospace Applications.

QUALITY ASSURANCE, CERTIFICATION & APPROVALS and HOSE TESTING

BS EN ISO 9001:2008

Aflex products are all manufactured in accordance with BS EN ISO 9001: 2008 Quality Management Systems independently assessed and registered by National Quality Assurance Limited (NQA).

FDA

The Materials used to manufacture the natural PTFE Tube liner conforms to FDA 21 CFR 177.1550, and the antistatic PTFE liner conforms to FDA 21 CFR 178.3297.

3-A SANITARY STANDARDS

The PTFE used in the liner is manufactured solely from materials which meet the requirements of the 3-A Sanitary Standards.

CHEMICAL MANUFACTURERS APPROVALS

Most of the major chemical manufacturing companies in the world have audited and/or approved Aflex Hose as a Hose Supplier.

BPSA LEACHABLES and EXTRACTABLES TESTING

Aflex Hose Natural and Antistatic PTFE Hose Liner Tube has been independently tested in accordance with BPSA recommendations, and found to be satisfactory.

Copies of the Test Report are available for specific assessments to be made.

CE MARKING (EUROPE ONLY)

Aflex has been assessed by Zurich Engineering and found to comply with the Pressure Equipment Directive 97/23/EC (European Community) Conformity Assessment Module D1, approved to CE Mark applicable hose products, accompanied by a Hose Usage Data Sheet, and a Declaration of Conformity.

ATTESTATIONS OF CONFORMITY TO ATEX DIRECTIVE 94/9/EC (POTENTIALLY EXPLOSIVE ATMOSPHERES)

Available for hose and assemblies for components used in Gas Zones 1 & 2 and Dust Zones 21 & 22, when applicable.

MATERIAL CERTIFICATION TO EN10204

Available for all the hose or hose assembly components.

CERTIFICATES OF CONFORMITY TO EN45014

Are available for all products.

HOSE TESTING

Each assembly is pressure tested to 1.5 times maximum working pressure before despatch, and pressure test certificates can be supplied.

HOSE CONFIGURATION & LENGTH CALCULATIONS

- FOR BEND RADIUS

■ Hose Configuration Requirements

Hose Assemblies are usually connected at both ends in service. They may then either remain in a fixed, or static configuration or in a flexing, or dynamic configuration.

Whether static or dynamic, the First Rule concerning the configuration of the hose is that the bend radius of the hose must never be less than the Minimum Bend Radius (MBR) for the hose as listed in the relevant hose brochure.

The most common situation when this is likely to occur is when the hose is flexed at the end fitting, with stress being applied to the hose at an angle to the axis of the end fitting. Typically, this happens either because the length of the hose is too short, or because the weight of the hose plus contents creates a stress at an angle to the end fitting.

The Second Rule, therefore, if possible, is to design the configuration to ensure that any flexing in the hose takes place away from the end fittings.

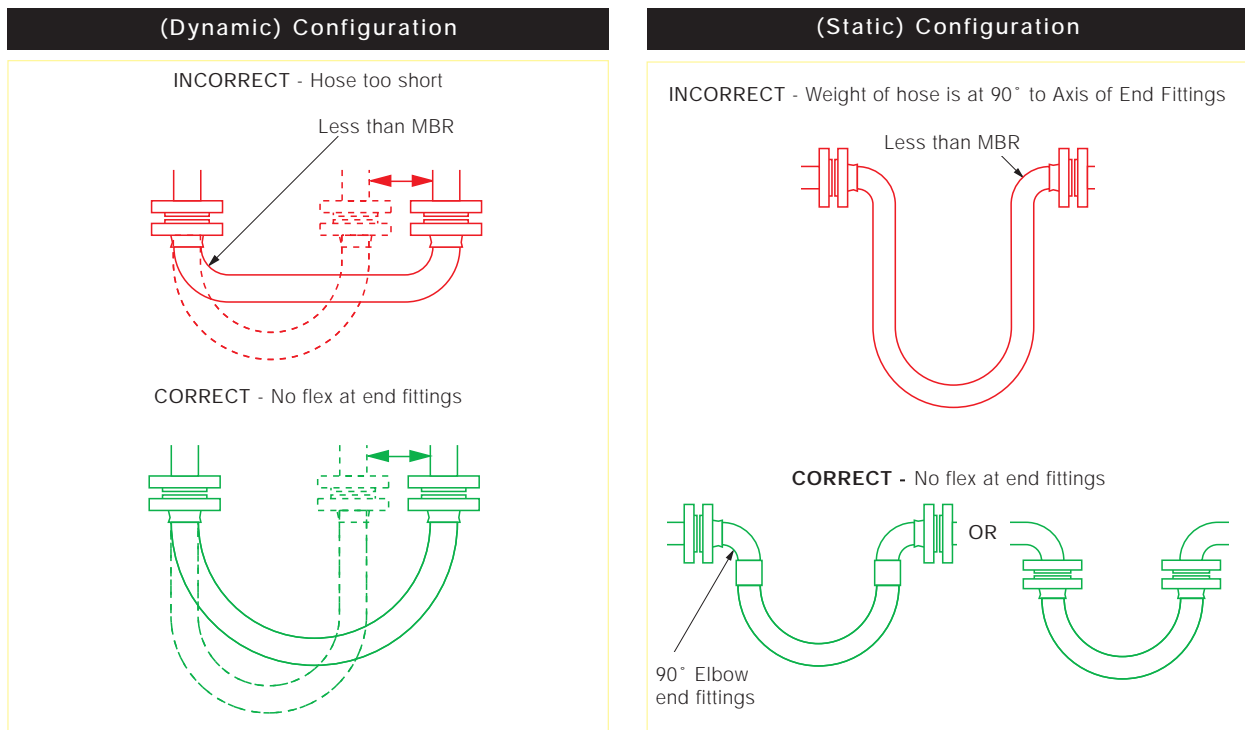

HOSE CONFIGURATION & LENGTH CALCULATIONS

- ABRASION & TORQUE

The Third Rule is that the hose configuration should always be designed, and supported where necessary, to avoid any possibility of external abrasion.

In some cases, the length, configuration and angle of the hose can be designed to avoid abrasion. In others, static or moving support frames or support wheels are required.

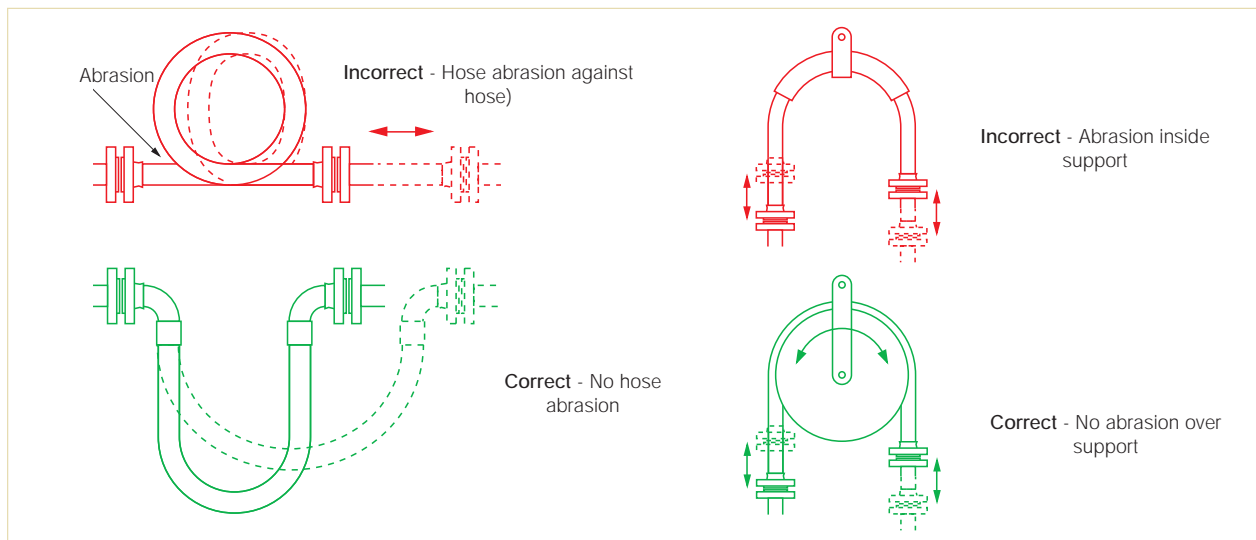

The Fourth Rule is that the hose must not be subjected to torque, either during connection, or as a result of the flexing cycle.

Torque (twist) in the hose can be applied during connection if the hose is accidentally twisted, or if the second end being connected is a screwed connection, and the hose is subjected to torque during final tightening.

In a flexing application, if any flexing cycle of the hose occurs in 3 dimensions instead of 2, then torque will also occur:

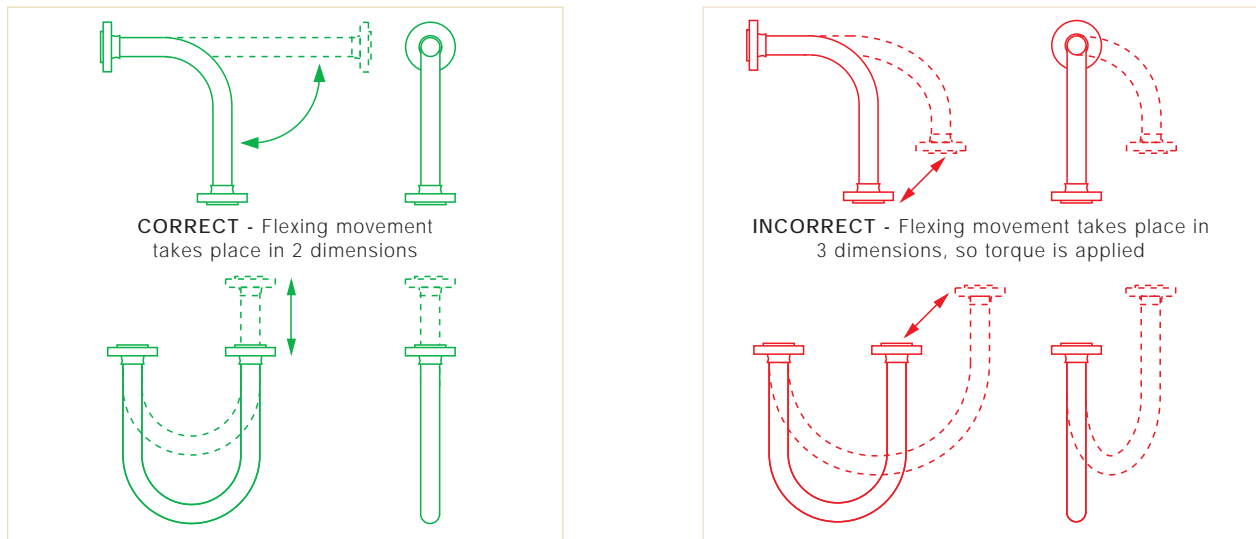

Both Corroflon and Bioflex hose have good resistance to a small level of torque, much better resistance than rubber or SS hose types, but it is still the best practice to take whatever steps are necessary to eliminate torque. If in doubt, consult Aflex Hose.

HOSE CONFIGURATION & LENGTH CALCULATIONS

- FOR BEND RADIUS

Calculating the Hose Length

The formula for calculating the bent section of the hose length around a radius is derived from the basic formula that the circumference of a circle = $2\pi R$, where R = the radius of the circle, and π = a constant, = 3.142.

So, if the hose goes around a 90° bend, which is $1/4$ of a full circumference, and the radius of the bend is R , then the length of the hose around the bend is = $1/4 \times 2\pi R$. Or half way round, in a U-shape, = $1/2 \times 2\pi R$.

Note :

In calculating the length of a hose assembly, the (non-flexible) length of the end fittings must be added in, also the length of any straight sections of hose, as in the following example:

Example :

To calculate the length for a 2" bore size hose with flange end fittings, to be fitted in a 90° configuration with one leg 400mm long, the other 600mm long.

$$\begin{aligned} \text{Length of Bent Section (yellow)} &= 1/4 \times 2\pi R (334) \\ &= 1/4 \times 2 \times 3.142 \times 334 = \quad \quad \quad \mathbf{525\text{mm}} \end{aligned}$$

$$\begin{aligned} \text{Length of top, Straight Section, including the top end fitting length} \\ &= 600 - 334 = \quad \quad \quad \mathbf{266\text{mm}} \end{aligned}$$

$$\text{Length of bottom end fitting} = \quad \quad \quad \mathbf{66\text{mm}}$$

$$\text{Total length of Hose Assembly} = 525 + 266 + 66 = \quad \quad \quad \mathbf{857\text{mm}}$$

Things to consider

- A hose will normally take the longest radius available to it to go around a corner, not the MBR! Also - always remember to include the **non-flexible** end fitting lengths.
- In dynamic applications, remember to always calculate the lengths for the most extended configuration during the flexing cycle, not the least extended.
- If the configuration is simply too complex for calculation, then obtain a length of flexible tubing of some kind, mark on paper, or a wall, or floor, or both where the connection points will be relative to each other, scaled down if necessary, then manually run the flexible tubing between them with full radii round bends. Measure the extended length, then scale up if necessary to determine the approximate length of the hose.

If in doubt, consult Aflex Hose.

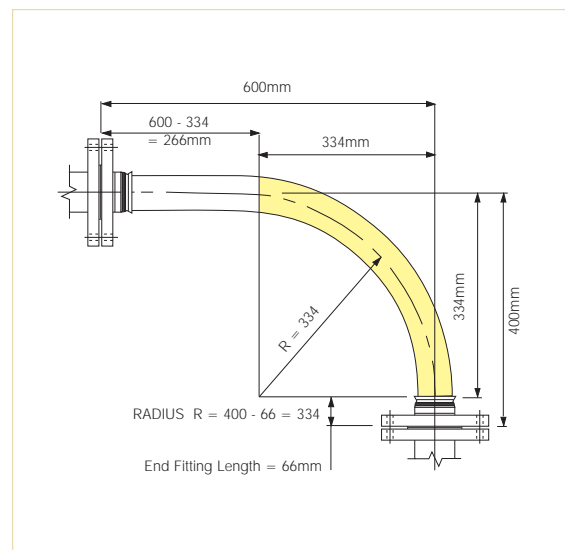
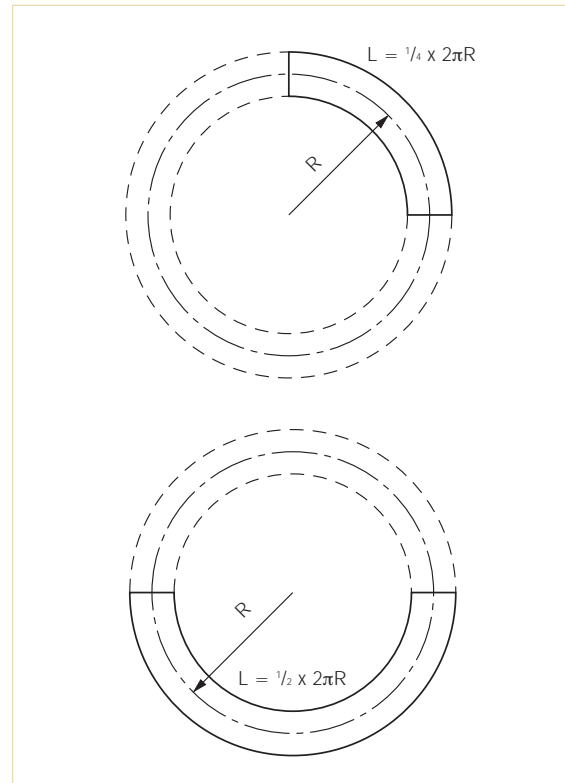

CONDITIONS OF SALE

General

Aflex PTFE hose products have not been designed or tested to be suitable for use in any **Aerospace, Medical Implantation or Radioactive applications** and such use is therefore strictly prohibited unless written approval from Aflex Hose USA, LLC has been given.

Aflex Hose USA, LLC will not accept liability for any failures of the Aflex Hose Products which are caused by customers failing to perform their Responsibilities as specified in these Conditions of Sale.

It is the customer's strict Responsibility to review all of the usage limitations given for the hose which he intends to use in an application, to ensure that the application conditions are in compliance with those usage limitations. The usage limitations are specified both on this page, in the Full Brochures for the relevant products on the Aflex Hose website. Customers must always consult the latest, up to date information, which is only available and downloadable from the Aflex website.

It must be accepted, however, that the usage limitations specified elsewhere in the Hose Product Information and on this page are intended as a guide only, since every possible factor in every type of application cannot possibly be covered. It is therefore the Customer's Responsibility to ensure the design suitability and safety of the products in their intended applications, giving particular consideration to the chemical and electrostatic compatibility of the fluids or gases passing through, the possibility of diffusion of fluid or gases through the PTFE hose lining, the possibility of external corrosive conditions, the types and likelihood of excessive mechanical abuse, such as abrasion (internal or external), crushing, excessive flexing or vibrations etc, and any excessive temperature and/or pressure "pulsing" conditions, all of which may cause premature hose failure. It is also the Customer's Responsibility to consider, and take account of the degree of risk involved in any hose failure, including the provision of adequate protection in the event of any risk to employees or the general public. In applications where any type of hose failure would lead to financial losses if the hose is not replaced immediately, it is the Customer's Responsibility to order and hold in stock spare hose(s) accordingly. It is also the Customer's Responsibility to advise Aflex Hose in writing if there are any special requirements for the hose, including cleaning, or drying, or extra testing requirements which are in addition to normal industrial standards.

If the Customer has any doubts concerning these or any other usage limitation or safety parameters, it is the Customer's Responsibility to consult Aflex Hose USA, LLC, to request a written response to any queries.

It is the Responsibility of the Customer to ensure that if the product is sold on, or passed on, however many times, that all the necessary information including this page and the Aflex Hose website address are also passed on to the final user, together with a specific requirement that the final user must review the usage limitations in terms of his own application.

Hose Service Life

It is not possible to guarantee a minimum service life for any of the Aflex Hose products which can be applicable for every type of application.

(For example, PTFE lined hose has been used in one application where it was cycled with hot steam, then cold water, also flexed every 17 seconds 24 hours per day, and the customer was very satisfied with a service life of 3 weeks before failure. In other light duty applications carrying pharmaceutical products, however, many Corroflon hoses are still performing satisfactorily after 20 years in service).

Service life predictions or guarantees can only be given in cases where all the relevant information concerning the application is given in writing to Aflex Hose, and Aflex Hose subsequently replies in writing prior to the order being placed.

If such a written undertaking is not sought and given, then Aflex Hose cannot be held liable for any hose product failure which the customer considers to be premature, excepting failures which are due to faulty materials or manufacturing defects.

24 Month Warranty

Aflex Hose USA, LLC warrants its products to be free from faulty materials or manufacturing defects from the date of the initial sale, for 24 months.

Product Failure

In the event of a product failure, Aflex Hose requests that the product should not be cut up or tampered with, but should be de-contaminated and returned to Aflex Hose, plus a decontamination certificate, for examination and analysis of the fault. The customer should also provide full details in writing of the application conditions under which the hose failed, including Pressure, Vacuum, Temperature, Flexing and any cycling of any of these, also the fluid and gases passing through the hose, and the total time that the hose has been in service. The customer may send his own witness to the examination if required. Aflex Hose will provide a full Non Conformance Report for the customer.

If faulty materials or a manufacturing defect in the hose was responsible for the failure to perform then, the maximum liability to be accepted by Aflex Hose would include the invoice value of the failed hose itself, or the invoice value of the whole customer order if appropriate, also any reasonable costs for removal and replacement of the hose, and costs for packing and despatching the failed hose back to Aflex Hose. Aflex Hose USA, LLC will not accept liability for any other consequential or financial losses, including, but not limited to loss of profits, loss of products or downtime costs.

Untested Hose for Self Assembly by Customers

Aflex Hose sometimes supplies "loose" hose, without end fittings attached to Self Assembly Customers, who will then cut the hose to length and attach end fittings to make up Hose Assemblies.

Self Assembly Customers must then accept the responsibility to carry out pressure testing of 100% of such assemblies to 1½ times the Maximum Working Pressure (MWP) if the hose as listed in the Full Product Brochure before supply for end use, to validate both the hose and the end fitting attachment.

When pressure testing hoses with a plastic or rubber outer cover, the cover will mask any signs of leakage for a time. It is therefore recommended that after the Hydrostatic Pressure Test, the hose should be tested at the MWP with air under water for a minimum test period of 5 minutes.

Unless the customer requests, and Aflex Hose confirm that their loose hose is pressure tested before supply, such testing is not normally applied by Aflex Hose, because this testing requirement is satisfied by the Self Assembly Customer during his own testing of the finished Hose Assembly.

The Self Assembly Customer must also accept responsibility for determining and approving the Design Suitability of the hose assemblies for their intended use before supply.

This includes determining and requesting or applying any special tests which may be identified as necessary to ensure suitability for the intended use.

Aflex Hose will only accept liability for its hose products which are assembled by Aflex Approved Self-Assembly Companies if all the hose and fitting components were supplied by Aflex Hose or approved for use by Aflex Hose, and they were assembled and tested in accordance with Aflex Hose's current Manufacturing and Testing Instructions, available to approved Self Assemblers in an I-Bay on the Aflex Hose website.

Untested Hose Assemblies

Aflex Hose is sometimes requested by customers to attach non-standard end fittings to hose assemblies which they supply, and in some cases it is not possible to connect these fittings to the pressure test system. In such cases a Concession not to test is obtained from the Customer, and a label is attached to the hose assembly, warning that it requires pressure testing before use.

Force Majeure

Aflex Hose USA, LLC shall not be liable for any delay or default in performing in accordance with any Customers' order if the delay or default is caused by conditions beyond its control, including, but not limited to wars, insurrections, strikes, natural disasters or performance failures by Carriers, sub-contractors or other third parties outside the control of Aflex Hose USA, LLC.

Legal System

This agreement and any sales thereunder shall be governed by the laws of the Commonwealth of Pennsylvania, without regard to conflicts of laws rules.

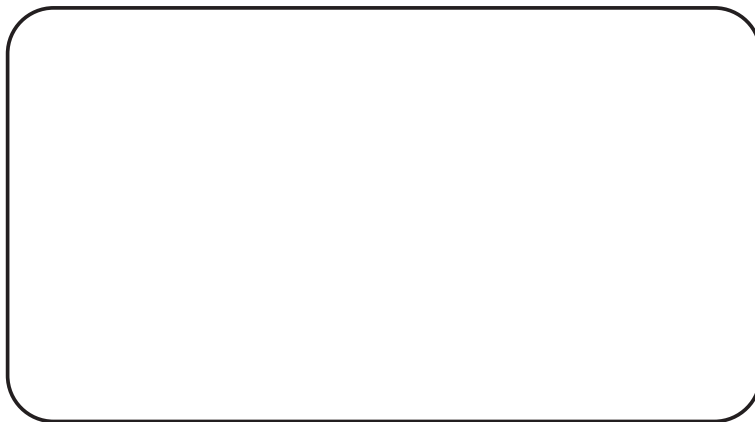

AFLEX HOSE LTD
Spring Bank Industrial Estate, Watson Mill Lane,
Sowerby Bridge, Halifax, West Yorkshire HX6 3BW

T: +44 (0)1422 317200 F: +44 (0)1422 836000
W: www.aflex-hose.com



AFLEX HOSE USA, LLC
6111 Keller's Church Road, Unit B
Pipersville, Pennsylvania, PA18947

T: 215 766 1455 F: 215 766 1688
W: www.aflex-hose.com



Certificate No. 1977