

# PHARMALINE & PHARMALEX

PTFE Lined Hoses



- SMOOTHBORE
- CHEMICAL RESISTANT
- SELF-CLEANING
- FLEXIBLE
- KINK RESISTANT

# CONTENTS

Front Cover	Page 1
Contents	Page 2
PTFE - The Optimum Choice For Hose Linings	Page 3
Pharmaline & Pharmalex Hose Descriptions	Page 4
Pharmaline & Pharmalex Specifications and Properties	Page 5
Pharmaline & Pharmalex Special Usage Conditions	Page 6
Aflex Hose and Pharmaline & Pharmalex	Page 7
Quality Assurance Certification & Approvals and Hose Testing	Page 8
How to Order Pharmaline & Pharmalex Hose Assemblies	Page 9
Part Numbers for Pharmaline & Pharmalex Hose Assemblies	Page 10
<b><u>HOSE</u></b>	
- Pharmalex & Pharmaline Hose Liners	Page 11
<b><u>FLANGE FITTINGS</u></b>	
- Flange Fittings	Page 12
<b><u>CAM AND GROOVE FITTINGS (CAMLOCKS)</u></b>	
- Male and Female Cam & Groove Fittings	Page 13
<b><u>SANITARY (TRICLOVER) FITTINGS</u></b>	
- Mini Sanitary & Sanitary Triclamp (Triclover) Fittings	Page 14
- 90° Elbow Sanitary Triclamp (Triclover) Fittings	Page 15
<b><u>BSP, NPT &amp; JIC THREADED FITTINGS (Not Lined)</u></b>	
- NPT & BSPT Fixed Male and NPT Fixed Female Fittings	Page 16
- BSP 60° Cone Seat Female Fittings and Lug-Type Female Fittings	Page 17
- 37° JIC Female Fittings & Adaptors	Page 18
<b><u>TUBE ADAPTOR FITTINGS</u></b>	
- Tube Adaptor (Grooved Standpipe) Fittings	Page 19
<b><u>PTFE DIP PIPES</u></b>	
- PTFE Dip Pipes, Straight or 90° Elbow	Page 20
<b><u>PHARMALINE &amp; PHARMALEX STANDARD AND PURETAG LABELLING &amp; COLOUR CODING</u></b>	Page 21
<b><u>CORRECT HOSE CONFIGURATION &amp; LENGTH CALCULATIONS</u></b>	
- for Bend Radius	Page 22
- for Abrasion & Torque	Page 23
- for Length Calculation	Page 24
<b><u>CONDITIONS OF SALE</u></b>	Page 25

# PTFE – THE OPTIMUM CHOICE FOR HOSE LININGS



PTFE, or Polytetrafluoroethylene, comprises long-chain molecules of carbon atoms, each linked to two fluorine atoms.

The fluorine atoms provide a helical spiral which surrounds the carbon chain and protects it.

It is this structure which creates the unique properties for which PTFE is well-known.

## Excellent Chemical Resistance

PTFE is renowned as the most chemically resistant material known. Only a very few, very unusual substances and conditions can affect it, like Fluorine gas at high temperature and pressure and liquid, boiling sodium metal.

PTFE lined hoses can therefore be used for a wider variety of chemicals than any other hose type, making it the ideal choice for very corrosive chemical applications and multi-product applications.

## Non-Stick Surface

The use of PTFE as a surface for cookware products has demonstrated to the world how easily cleanable PTFE surfaces are.

This means that PTFE lined hoses can be purged 100% clean more quickly, easily and reliably than any other type of hose.

## Excellent Temperature Range

The cookware application also demonstrates another of PTFE's many attributes - temperature resistance. PTFE itself can be used as a hose liner at temperatures from  $-150^{\circ}\text{C}$  up to  $+260^{\circ}\text{C}$ , dependent upon the hose design and the application conditions.

This is the widest temperature range of any rubber or plastic hose lining material.

## Very High Electrical Resistance

Most aerospace electrical wiring has a PTFE cover, due to the excellent electrical resistance of PTFE. This property is, however, a disadvantage in some hose applications where there is a risk of developing an electrostatic charge inside the hose bore. Aflex Hose have developed a non-contaminant, FDA and USP Class VI compliant solution to this problem.

## Hose Design

The only issue with PTFE as a hose lining material is the best way it can be integrated in to the hose design. This is where Aflex Hose have a proven record of success over the last 30 years.

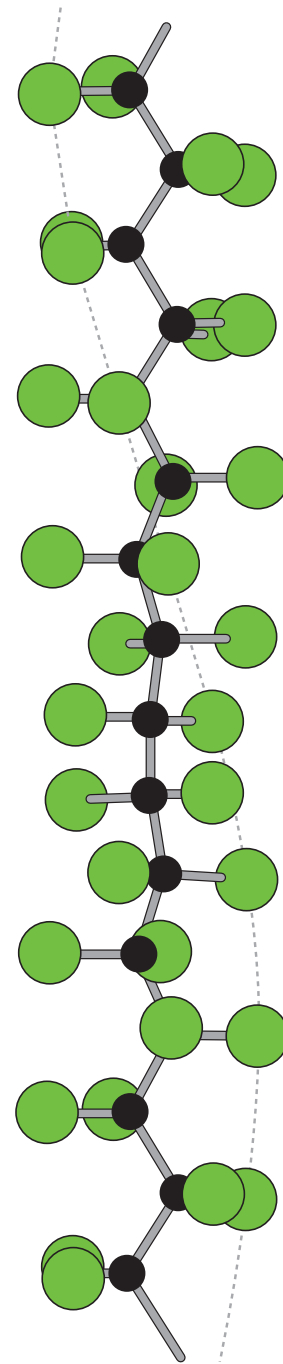

Section from a PTFE Molecule, 16 Angstrom Units long



Fluorine Atom



Carbon Atom

# PHARMALINE & PHARMALEX HOSE DESCRIPTIONS

## PHARMALINE HOSE

### INTRODUCTION

Pharmaline hose was designed and developed to provide customers with an improved high purity hose product which combined all the requirements they had requested for Pharma and Biotech applications, particularly the need for improved flexibility.

Pharmaline hose not only supercedes but also improves upon the wide variety of alternative products currently available.

### CONSTRUCTION

Pharmaline is built around a patented PTFE hose liner design, which is smooth bore inside but convoluted outside to generate excellent flexibility combined with "hoop strength".

A stainless wire and stainless steel wire braid reinforcement adds to the kink resistance, crush resistance and the resistance of the hose to both pressure and vacuum. For sizes  $\frac{3}{4}$ " and above, a SS helical wire is wound in to the convolutions to further reinforce the hose design.

This reinforced PTFE construction is therefore strong enough to withstand full vacuum and kinking without the need for either internal convolutions or the need to bond the liner to an outer cover, making it an ideal hose liner design, and a significant improvement upon standard products currently available. (Competitor's products include a non-FDA approved adhesive layer outside a thin wall PTFE or FEP liner tube, which can leach into the process fluid through small pinholes and cracks).

Finally, an outer cover of Platinum Cured Silicone rubber is extruded on to the braid, with a super-smooth surface finish to aid external cleaning.

### PHARMALINE HOSE - THE BEST FLEXIBLE HOSE FOR BIOPHARM APPLICATIONS

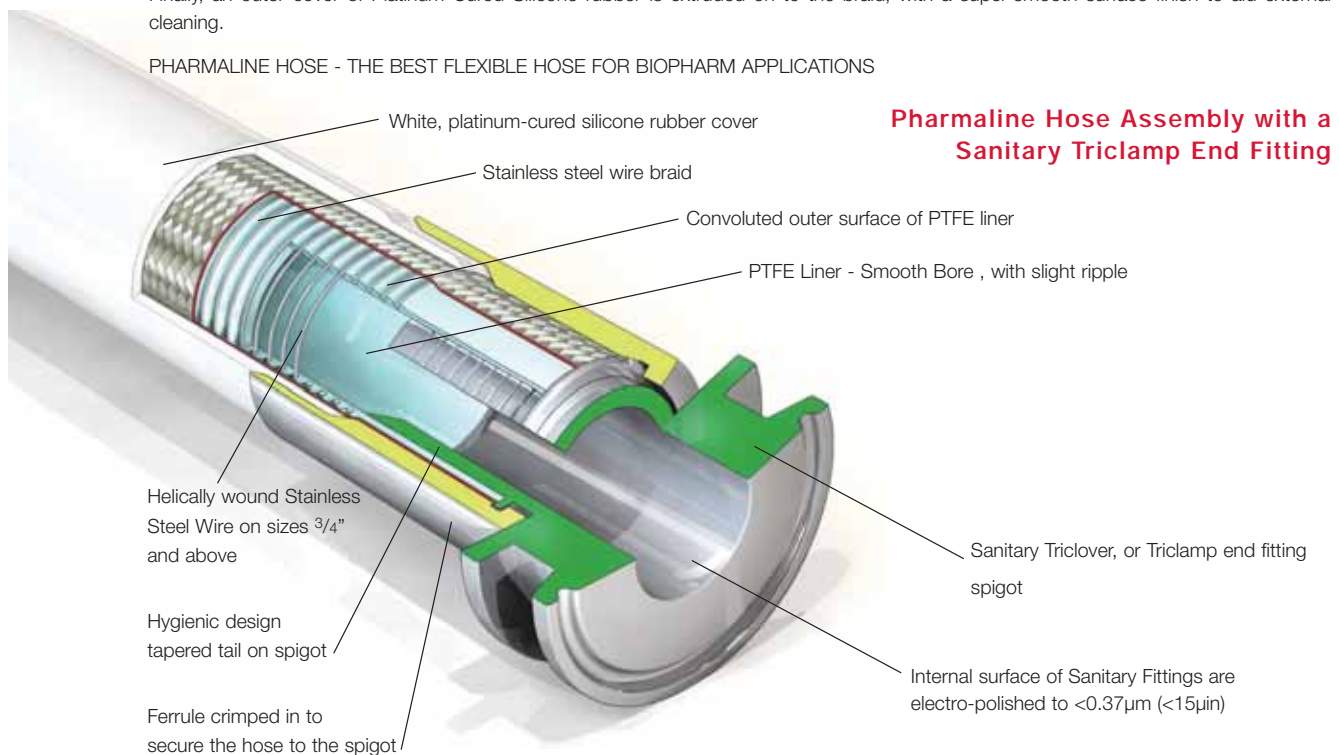

The primary application area for Pharmaline is in high purity pharmaceutical, biotech, chemical and foodstuffs plants where ease of cleaning the hose, both internally and externally is required.

Pharmaline is also very suitable for use in other general industrial applications, particularly those where hot fluids or gases are being passed, if there is any risk of burns due to accidental touching of the hose – for example, hot oil or steam transfer applications.

## PHARMALEX HOSE

### INTRODUCTION

Pharmalex hose was designed to provide a lightweight alternative version of Pharmaline hose, for light duty, low pressure applications.

### CONSTRUCTION

The same as Pharmaline hose, except there is no SS wire braid, no helix wire, and the platinum cured silicone rubber is transparent, not white. Pharmalex is only available in bore sizes up to 1"



# PHARMALINE & PHARMALEX SPECIFICATIONS & PROPERTIES



## SPECIFICATIONS FOR PHARMALINE GP AND AS

Hose Bore Size		Actual Hose Bore Size		O/D of Cover		Minimum Bend Radius		Maximum Working Pressure		Burst Pressure		Weight per Unit Length		*Maximum Continuous Length	
in	mm	in	mm	in	mm	in	mm	Psi	Bar	Psi	Bar	lb/ft	kg/mtr	Ft	Mtrs
1/4	6.4	0.270	6.8	0.460	11.6	3/4	19	2000	130	8000	520	0.11	0.17	60	18
3/8	9.5	3/8	9.5	0.610	15.5	1	25	1500	100	6000	400	0.14	0.22	60	18
1/2	12.7	1/2	12.7	0.770	19.5	1 1/2	38	1000	70	4000	280	0.25	0.37	60	18
5/8	16.0	5/8	16.0	0.960	24.4	2	50	950	65	3800	260	0.35	0.52	60	18
3/4	19.0	3/4	19.0	1.070	27.3	2 1/2	63	900	60	3600	240	0.42	0.65	60	18
1	25.4	1	25.4	1.370	34.8	4	100	750	50	3000	200	0.57	0.88	60	18
1 1/4	32.0	1.200	32.5	1.785	45.30	5 1/4	130	650	44	2600	180	0.85	1.30	60	18
1 1/2	38.0	1.530	38.8	2.035	51.7	6.70	170	550	38	2291	158	1.14	1.698	55	17
2	50.0	2.030	51.5	2.560	65.7	8.270	210	400	28	1783	123	1.58	2.355	42	13

## SPECIFICATIONS FOR PHARMALEX GP AND AS

Hose Size		Hose Actual I/D		O/D over Silicone Cover		Minimum Bend Radius		Maximum Working Pressure		Burst Pressure		Weight per Unit Length		*Maximum Continuous Length	
in	mm	in	mm	in	mm	in	mm	Psi	Bar	Psi	Bar	lb/ft	kg/mtr	Ft	Mtrs
1/4	6.4	0.270	6.8	0.456	11.6	1 1/4	30	109	7.5	435	30	0.06	0.09	60	18
3/8	9.5	0.375	9.5	0.610	15.5	1 1/2	38	87	6.0	348	24	0.09	0.14	60	18
1/2	12.7	0.500	12.7	0.767	19.5	2 1/2	63	84	5.8	334	23	0.14	0.21	60	18
5/8	16.0	0.625	16.0	0.960	24.5	3	75	75	5.0	300	20	0.18	0.27	60	18
3/4	19.0	0.750	19.0	1.075	27.3	4	100	62	4.3	247	17	0.21	0.32	60	18
1	25.4	1.000	25.4	1.370	34.8	6	150	52	3.5	203	14	0.33	0.49	60	18

\*Sizes up to 1" are available in continuous lengths up to 120 ft (36 mtrs) to special order

### PRESSURE TESTING

Before despatch, all hose assemblies are hydrostatically pressure tested to 1.5 times the Maximum Working Pressure of either the hose or the end fitting, whichever has the lower M.W.P. A Test Certificate can be issued if required.

Loose lengths of hose supplied for self-assembly by the Customer are not pressure tested, and so should be gas pressure tested (under water) before use by the Customer after assembly with end fittings.

### TEMPERATURE LIMITATIONS

Usable from -73°C, -100°F up to +204°C, +400°F.

Reduce maximum working pressures by 1 1/2% for every 1°C (1.8°F) above 130°C (266°F).

### VACUUM LIMITATIONS

Useable at full vacuum up to 140°C, 284°F.

### FLOW RATES

More than 2x the flow rates for convoluted bore PTFE lined hose designs due to laminar flow (convoluted hose creates turbulent flow which reduces flow rates). Consult Aflex Hose for specific flow rate information.

### GAS PERMEABILITY

More than 2x lower permeability than other smooth bore hose designs, due to the heavy compression applied to the PTFE during processing, which reduces micro porosity.

### "ROLLING U" TEST FOR FLEX LIFE

More than 15x the flex life to failure compared with all other types of competing PTFE lined hose products.

### FLEXIBILITY

Much less force to bend than any other smooth bore PTFE lined hose product.

### KINK RESISTANCE

Much more resistant to kinking than any other smooth bore PTFE lined hose product.

# PHARMALINE & PHARMALEX HOSE : SPECIAL USAGE CONDITIONS

## Cleaning & Sterilising Systems - CIP, SIP and Autoclave

CIP & SIP – The primary consideration is whether the cleaning and purging cycle is likely to develop an electrostatic charge on the internal surface of the liner, in which case AS is required.

AS hose and Static charge generating systems are fully described on page 11.

CIP systems using high electrical resistivity solvents like Toluene will require AS hose.

Another problem arises when the cleaning fluids or WFI or steam are purged out of the line using nitrogen, compressed air or another gas, because droplets of liquids or water in the gas then generate a multi-phase condition until they are cleared out, which will generate a static charge, and so will require AS hose.

In applications where an AS hose is not acceptable (in spite of the full approvals ratings, see page 8) it will be necessary to consult with Aflex Hose for a solution.

Autoclave – Autoclave sterilisation does not normally involve any high flow rates through the hose bore, so static is not a problem. Bioflex grades GP and AS, with SS or HB braids can be autoclaved an indefinite number of times throughout their normal service life.

The rubber covered grades, RC and SI, are also able to withstand many autoclave cycles at normal autoclave temperatures (121°C, 250°F), although eventually the rubber may discolour and/or degrade. Consult Aflex Hose for more specific information.

## PTFE Hose - Use with Halogens

PTFE hose liners can react chemically with Fluorine, Chlorine Trifluoride and Molten Sodium Metal, and so must not be used with these chemicals.

When PTFE lined hose is used with the halogens Chlorine and Bromine, or any corrosive halogen compounds which diffuse easily and are gaseous for example HF or HCL gas, or phosgene, then trace quantities may diffuse through the PTFE liner to the outside.

Only trace quantities are required, mixed with atmospheric moisture, to create a serious corrosion condition with stainless steel wire braid in particular. If these conditions apply, consult Aflex Hose for a more suitable alternative hose product.

## “Penetrating” Fluids and Gases

Like other plastics and rubbers, in certain special circumstances PTFE is sometimes subject to diffusion through the tube wall, dependant upon the nature of the chemical, and the pressure and temperature of operation.

As mentioned above, Gaseous Halogens represent a specific problem. Automotive fuels, on the other hand, diffuse much less through PTFE than through other rubbers and plastics.

Some other types of penetrating fluids can also diffuse through PTFE to varying degrees, which may or may not present a problem. Known examples are sulphur trioxide, glacial acetic acid and methyl methacrylate.

Consult with Aflex Hose if these, or any other gases or fluids which are known to be penetrating are to be used.

## Gas/Fluid Cycling

There are some applications where the fluid passing through the hose turns into a gas, then back into a fluid, then into a gas etc., in a cyclic sequence.

This is normally associated with changes in temperature and/or pressure.

For complex reasons these conditions are extremely damaging to the hose liner, whatever material it is made from.

For example, hoses are sometimes used to pass steam, water, steam etc into rubber moulding presses, in order to heat the mould, then rapidly cool it before reheating in the next cycle. Hoses of all types fail rapidly in such an application, and PTFE lined hose is no exception.

Consult Aflex Hose for further information if these conditions apply.

## Connecting Assemblies for use in Applications

The lengths of hose assemblies, and their configuration and use when connected into the application must always be in accordance with the Hose Configuration information at the end of this literature.

When being connected for use in applications, the end fittings on hose assemblies must be connected to correct mating parts in the correct way, using the correct tools - spanners, clamps, nuts and bolts etc.

The connections must be sufficiently tightened to ensure that the joint is leak-free, but must not be over-tightened as this can damage the sealing surfaces, especially with PTFE lined and flared end fittings.

In applications involving the transfer through the hose of expensive or dangerous fluids or gases, the connections must be pressure tested first before being put in to service. This should be done with some harmless media, like water or compressed air, to 1 1/2 times the maximum working pressure of the hose assembly, as defined in this brochure.

If in doubt, consult Aflex Hose for advice.

## Special Applications

Aflex Hose PTFE lined hose products are not acceptable for use in the following, special applications:

- Radioactive Applications involving high energy radiation, including Gamma radiation (degrades PTFE).
- Medical Implantation Applications (Not tested for use).
- Aerospace Applications (exclusive contract applies).
- Applications on all types of USA Military Equipment, including tanks, vehicles, weapons, FCS equipment and all others (exclusive contract applies).

# AFLEX HOSE and PHARMALINE & PHARMALEX



## AFLEX HOSE LTD

Aflex Hose was established as a PTFE hose manufacturing company in 1973 and, since then, has led the world in inventing and developing all the major innovations in PTFE hose design for use in process fluids transfer applications.

PHARMALINE and PHARMALEX are the latest additions to the Aflex Hose product range.



Technically trained Aflex Hose sales staff are available to respond quickly and effectively to every kind of enquiry, and to advise the optimum hose solution for any application.

## OTHER PRODUCTS

Aflex Hose also manufactures many more PTFE hose products for use in specific Process Fluid transfer applications. Corroflon, Bioflex and Corroline are described in other brochures and information is also available on the Aflex Hose website

## ROLLING 'U' TEST

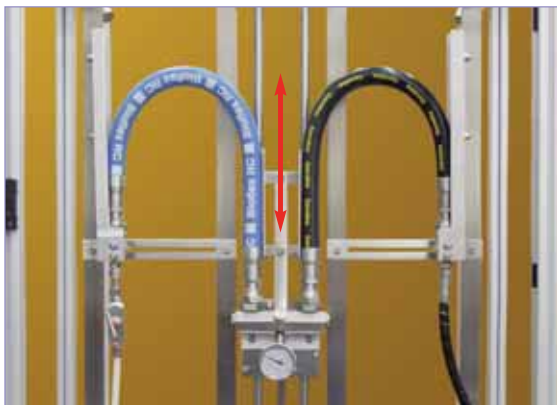

The "Rolling U" test is one of many tests carried out at Aflex Hose to prove hose suitability in application.

The "Rolling U" Test is designed to determine the flex life capabilities of hose products. Pharmaline has proved to have many times the flex life to failure when tested alongside the best of the competitors' PTFE lined hose products.

## TOTAL MANUFACTURE

The primary reason for the success of the Aflex Hose range of products is that Aflex is the only PTFE hose company in the world to carry out all the hose design and manufacturing operations in house, from raw materials to finished products, at Aflex Hose plants in Yorkshire (UK) and Pennsylvania (USA).

- PTFE powder is extruded into tube and convoluted.
- Stainless steel wire is wound and braided onto the tube.
- Rubber extruders are used to apply external covers.
- End fittings are machined from bar stock on state of the art CNC lathes.
- And, finally, the hoses are assembled to individual customer requirements, tested and dispatched to end users.

**Because Aflex Hose perform all these operations in house, Aflex is able to achieve unbeatable levels of build quality, design excellence and economy of scale, which are unmatched by our competitors.**



# QUALITY ASSURANCE CERTIFICATION & APPROVAL and HOSE TESTING

## **BS EN ISO 9001:2008**

Aflex products are all manufactured in accordance with BS EN ISO 9001: 2008 Quality Management Systems independently assessed and registered by National Quality Assurance Limited (NQA).

## **USP CLASS VI and ISO 10993-5, 6, 10 and 11 GUIDELINES**

Natural and Antistatic PTFE Hose Liners, Platinum Cured Silicone Rubber Covers (White and Clear) and EPDM Rubber Cover (Blue) have been independently tested in accordance with USP protocols and are found to conform to the requirements of USP Class VI Chapter <88>.

Natural and Antistatic PTFE Hose Liners now also meet the more stringent USP Class VI and ISO 10993-6,10 and 11 guidelines at 121°C (250°F) with a “no reaction” classification.

Natural and Antistatic PTFE Hose Liners and Platinum Cured Silicone Rubber Covers (White and Clear) have also been tested in accordance with USP protocols and are found to conform to the requirements of USP Class VI <87>, the L929 MEM Elution Test and are considered non-cytotoxic.

Natural and Antistatic PTFE Hose Liners have now been further tested and have passed the more stringent USP Class VI and ISO 10993-5 guidelines at 121°C (250°F).

## **FDA**

The Materials used to manufacture the natural PTFE Tube liner conforms to FDA 21 CFR 177.1550, and the antistatic PTFE liner conforms to FDA 21 CFR 178.3297.

## **3-A SANITARY STANDARDS**

The PTFE used in the liner is manufactured solely from materials which meet the requirements of the 3-A Sanitary Standards.

## **PHARMACEUTICAL MANUFACTURERS APPROVALS**

Most of the major pharmaceutical manufacturing companies in the world have audited and/or approved Aflex Hose as a Hose Supplier.

## **BPSA LEACHABLES and EXTRACTABLES TESTING**

Aflex Hose Natural and Antistatic PTFE Hose Liner Tube has been independently tested in accordance with BPSA recommendations, and found to be satisfactory.

Copies of the Test Report are available for specific assessments to be made.

## **CE MARKING (EUROPE ONLY)**

Aflex has been assessed by Zurich Engineering and found to comply with the Pressure Equipment Directive 97/23/EC (European Community) Conformity Assessment Module D1, approved to CE Mark applicable hose products, accompanied by a Hose Usage Data Sheet, and a Declaration of Conformity.

## **ATTESTATIONS OF CONFORMITY TO ATEX DIRECTIVE 94/9/EC (POTENTIALLY EXPLOSIVE ATMOSPHERES)**

Available for hose and assemblies for components used in Gas Zones 1 & 2 and Dust Zones 21 & 22, when applicable.

## **MATERIAL CERTIFICATION TO EN10204**

Available for all the hose or hose assembly components.

## **CERTIFICATES OF CONFORMITY TO EN45014**

Are available for all products.

## **HOSE TESTING**

Each assembly is pressure tested to 1.5 times maximum working pressure before despatch, and pressure test certificates can be supplied.

# HOW TO ORDER PHARMALINE & PHARMALEX HOSE ASSEMBLIES



## PHARMALINE & PHARMALEX HOSE ASSEMBLIES

Pharmaline & Pharmalex hose is custom built into hose assemblies after the hose size and grade, length and end fittings have been selected.

The specification and information contained in this brochure can be used to make these selections, but if there are any doubts concerning the hose usage limitations or performance capabilities, customers should request expert advice from Aflex Hose.

## SELECTING THE HOSE GRADE

There are two types of PTFE hose liner tube available, natural GP grade and antistatic (black) AS grade, fully described on page 11

## SELECTING THE HOSE ASSEMBLY LENGTH

The lengths of Pharmaline & Pharmalex hose assemblies are as specified by the customer and the length is measured from the sealing face at one end fitting to the same at the other end of the hose.

Length tolerances are normally +5% -0%.

Maximum lengths are given under Specifications on page 5

Minimum lengths can be calculated from the configuration data on pages 22 - 25.

Lengths may be stated in Feet & Inches, Inches or decimal Metres or Millimetres. Units used must be stated.

## SELECTING THE END FITTINGS

The range of standard end fittings and materials are given on pages 12 - 20.

## STAINLESS STEEL END FITTING MATERIALS

Non-Lined Spigots (including Flange Retainers) - are all made from Grade 316L SS

Cam and Groove Female Fittings - are made from Grade 316C SS (Body) and 316L SS (Spigot)

Swivelling Nuts and Flanges - are all made from Grade 304 SS

Ferrules - ferrules are made from Grade 304 SS.

The equivalent specification for the different Grades of Stainless Steel are listed below:

### Specification Equivalents List

Grade	BS - British Standard	AISI - American Standard or C = Casting Grade	EN - European Norm
316L SS	BS 316 S11	AISI 316 L	EN 1.4404
316C SS	BS 316 C16	CF8M	EN 1.4408
304 SS	BS 304 S15	AISI 304	EN 1.4301

To special order, end fitting components can be made in non-standard grades of SS such as 1.4571, 1.4435, or other materials such as Hastelloy or Monel

## HOW TO ORDER

The quantity, hose size, grade, length and fittings must be specified in full.

**EITHER** by a full, written description. The hose grade can be specified by the code initials e.g. "Pharmaline AS" defines an antistatic PTFE lined Pharmaline hose.

The quantity, length and fittings can then be written in - e.g. "4 off x 1" bore Pharmaline AS hose x 3.00 metres long. Both ends ANSI 150# S/S Flanges".

**OR** by Part Numbers, as defined on page 10

Any special requirements relating to the hose construction, or information required on Tags, or Certificates, or special testing requirements, must be specified in full on the enquiry or purchase order.

## CONDITIONS OF SALE

Pharmaline and Pharmalex hose and hose assemblies are only supplied on the basis that the customer has read and accepted the Conditions of Sale as given on page 25.

# PART NUMBERS for PHARMALINE and PHARMALEX HOSE ASSEMBLIES

Pharmaline and Pharmalex Hose Assemblies are defined by an individual Part Number made up of ⑤ entries:

Hose Size	Size Part No.
1/4"	04
3/8"	06
1/2"	08
5/8"	10
3/4"	12
1"	16
*1 1/4"	*20
*1 1/2"	*24
*2"	*32

\* These sizes are only available in Pharmaline

4 & 5

Assembled End Fitting Description *All Components in Stainless Steel	End Fitting Part No.
JIC Female	02
Fixed Male Pipe, NPT Thread	03
Fixed Female Pipe, NPT Thread	06
JIC-to-NPT Male Union	08
JIC-to-Female Male Union	08F
Straight Sanitary Tri Clamp, 1.984" Diameter	
0.870" Exit Diameter (Standard)	10
1.370" Exit Diameter (Step-Up)	10/S
Straight Mini Sanitary, 0.984" Diameter	
0.370" Exit Diameter (Standard)	11
0.620" Exit Diameter (Step-Up)	11/S
*ANSI 150# Swivelling Flange	12
Cam and Groove, Locking Arm Swivelling Female	16
Cam and Groove Male	17
Tube Adaptor	32
Tube Adaptor with Nut and Ferrule	32/FN

Hose Type	Type Part No.
Pharmaline GP	PHL
Pharmaline AS (Antistatic PTFE Liner)	PHLAS
Pharmalex GP	PHX
Pharmalex AS (Antistatic PTFE Liner)	PHXAS

\*For flange only, Carbon Steel Zinc Plated, add "/ZP" or Epoxy coated add "/EC"

Length
The overall hose length between the sealing faces at each end is given as the <u>Length Part No.</u> , either in decimal Metres followed by "m" or Inches followed by "in".

**Note:** ELBOWS - Elbow Fittings for all types are indicated by adding "/90°" for 90° elbows.

**Example:** a 3/4" bore Pharmaline Hose Assembly with an Antistatic PTFE Liner.

End (1) - a 3/4" ANSI 150# Swivel Flange

End (2) - a 90° Elbow Sanitary Triclamp

Length - 4ft 6 inches

Part No: 12-PHLAS-54in-12-10/90

① ② ③ ④ ⑤

# PHARMALINE & PHARMALEX HOSE - GP and AS PTFE LINERS

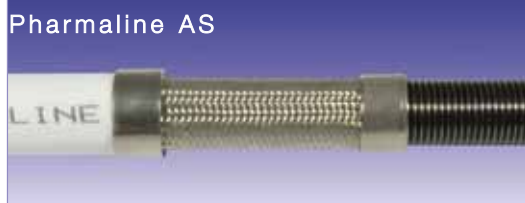
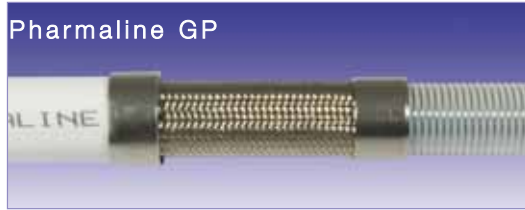

## PURPOSE - GP GRADES

GP is the 'General Purpose' grade, for use in all applications where fluids or gases are being conveyed which do not generate a risk of static charge development (see "AS").

### Design & Approval

GP Grade has a virgin PTFE liner, manufactured from hose grade PTFE which conforms to the requirements of:

FDA 21 CFR 177.1550

Both the PTFE liner tube and the platinum cured silicone rubber cover have been tested and conform to the requirements of **USP Class VI** both at normal temperatures and at 121°C (250°F) - see page 8.

Pharmaline hose (but not Pharmalex Hose) in sizes 3/4" and above includes a Grade 304 SS wire helically wound in the external convolutions, to reinforce the hose against kinking.

## EC - ELECTRICAL CONTINUITY

Electrical continuity requires that the hose assembly supplied is electrically continuous, or conductive, between metal end fittings at each end of the hose. This can apply whether the hose is GP or AS grade.

The requirements for electrical continuity are specified in the German Document BRG132, and the Specification EN ISO 12115, tested to EN ISO 8031 Clause 3.7, which requires that for hose assemblies with a resistance between fittings of  $\leq 10^2$  ohms, a letter "M" can be applied, or  $\leq 10^6$  ohms, a letter "Ω" can be applied.

**Pharmaline Hose Assemblies are all electrically continuous, and all meet the requirements of both "M" and "Ω", but are not stamped unless requested.**

**Pharmalex Hose Assemblies are not electrically Continuous.**

## PURPOSE - AS GRADES

AS Grade is an essential requirement in applications where there is the risk of an electrostatic charge build-up on the inside surface of the PTFE tube which may then discharge through the tube wall. Media passing through which create such a risk are fluids which have a Conductance of less than  $10^{-8}$  S/m (Siemens per Metre), or  $10^4$  pS/m such as fuels, solvents, freons, some WFI (ultra-pure "Water for Injection") and non-polar organics which are being transferred at a medium to high flow velocity. All twin or multi phase media, and any non-mixing media, such as powder in air, or water droplets in steam, in gases or in oil, also colloidal fluids constitute a particular hazard for static charge generation, and always require grade AS.

### Design & Approval

AS Grade hose has an anti-static PTFE liner manufactured from FDA approved PTFE, and less than 2.5% of "high purity" Carbon Black material to FDA requirement 21 CFR 178.3297 and European Commission Directive 2007/19/EC. AS Grade also conforms to the requirements of USP Class VI both at normal temperatures, and at 121°C (250°F) - see page 8.

### Specifications

When "AS" (Antistatic) grade hose is specified, then the hose supplied will be in accordance with the requirements of BS5958 Part 2, 1991 Clause 19.3, when tested in accordance with EN ISO 8031 Clause 3.1, which requires that the resistance between a plug inserted 25mm into the bore at the end of the hose assembly, and one of the metallic end fittings should be less than  $10^8$  ohms.

NOTE: When in service, at least one end fitting must be connected to earth, to permit dissipation of the static charge from the end fitting.

# PHARMALINE & PHARMALEX SWIVEL FLANGE FITTINGS

## Flange Specification

- ANSI B16.5 (also ASME B16.5) Class 150# and 300#
- DIN PN10, PN16 and PN40
- JIS 10K
- Other Pressure Ratings and Flange Specifications are also available.

Note: DIN PN10, 16 and 40 Flanges all have identical dimensions, and so are fully interchangeable.

## Pressure Ratings

- ANSI 150# = 230 psi (16 Bar), ANSI 300# = 460 psi (32 Bar).
- DN PN10 = 145 psi (10 Bar), DN PN16 = 230 psi (16 Bar), DN PN40 = 580 psi (40 Bar)

## End Fitting Materials

- Flanges in Grade 304 SS
- Flange Retainers in Grade 316L SS
- Ferrules, in Grade 304 SS

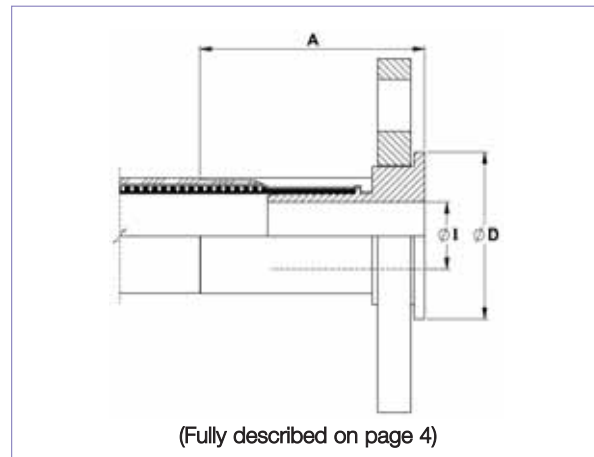

Nominal Hose Size		Fitting Length A		Flared Diameter D				Fitting Inside Diameter I	
in	mm	in	mm	ASA150		PN10/16		in	mm
				in	mm	in	mm		
1/2	13	2.00	51	1.38	35.0	1.77	45.0	0.38	9.53
3/4	20	2.56	65	1.69	42.9	2.28	58.0	0.63	15.88
1	25	2.64	67	2.00	50.8	2.68	68.0	0.80	20.24
*1 1/2	40	3.74	95	2.88	73.0	3.47	88.0	1.25	31.75
*2	50	3.78	96	3.63	92.0	4.02	102.0	1.75	44.45

\*These sizes are not available in Pharmalex Hose.

# PHARMALINE & PHARMALEX FEMALE and MALE CAM & GROOVE FITTINGS



## ■ End Fitting Specification

- Generally in accordance with A-A-59326 (replaces MIL-C-27487) and EN14420-7:2004 (replaces DIN 2828), and all are fully interchangeable.

## ■ Temperature and Pressure Ratings

- All sizes up to 230 psi (16 Bar)
- Up to 212°F (100°C) Buna N Gasket or 400°F (200°C) FEP Gasket.

## ■ End Fitting Materials

- Female Spigot and Male in Grade 316L SS
- Female Body in Grade 316C SS
- Ferrules, in Grade 304 SS
- Standard Gasket is Buna N (Nitrile) Rubber.
- FEP encapsulated Silicone Rubber Gaskets also available.

## SWIVELLING, LOCKING ARM FEMALE CAM AND GROOVE FITTINGS

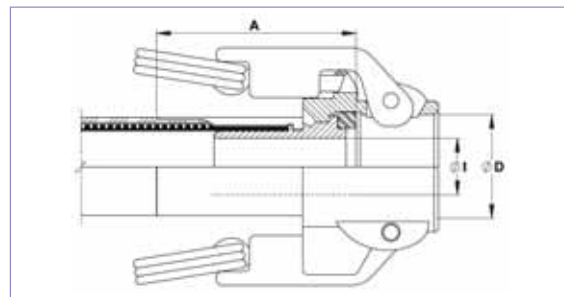

Nominal Hose Size		Fitting Length A		Cam Sleeve Inside Diameter D		Fitting Inside Diameter I	
in	mm	in	mm	in	mm	in	mm
3/4	20	2.64	67	1.26	32	0.63	15.88
1	25	2.72	69	1.46	37	0.75	19.05
*1 1/2	40	3.62	92	2.13	54	1.25	31.75
*2	50	3.62	92	2.52	64	1.75	44.45

## MALE CAM AND GROOVE FITTINGS

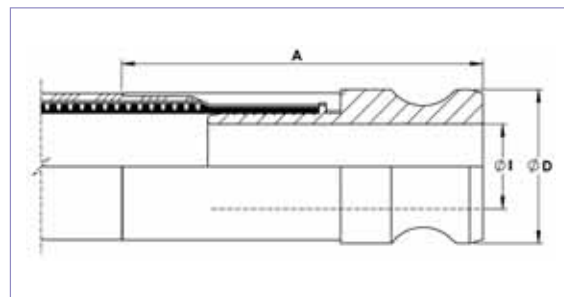

Nominal Hose Size		Fitting Length A		ØD		Inside Diameter I	
in	mm	in	mm	in	mm	in	mm
3/4	20	2.87	73	1.260	32	0.625	15.88
1	25	3.31	84	1.456	37	0.75	19.05
*1 1/2	40	4.53	115	2.106	54	1.25	31.75
*2	50	5.04	128	2.480	63	1.75	44.45

\*These sizes are not available in Pharmalex Hose.

# PHARMALINE & PHARMALEX SANITARY & MINI SANITARY TRICLAMP (TRICLOVER) FITTINGS



## ■ End Fitting Specification

- Generally in accordance with BS4825:Pt 3 and ASME BPE-a-2007, or DIN 32676 (The DN sizes)

## ■ Temperature and Pressure Ratings

For Standard Clamp and Standard (EPDM) Gasket

- Pressures up to 230 psi (16 Bar)
- Temperatures up to 250°F (120°C)
- Higher Pressures and Temperatures with Special Clamps and Gaskets.

## ■ End Fitting Materials

- Fittings in AISI 316L = EN 1.4404 = BS 316 S11. Internal Bores all Electropolished to <math><15\mu\text{m Ra}</math> (<math><0.375\mu\text{mtr}</math>).
- Ferrules, in Grade 304 SS.

## ■ \*Outlet Diameters (Inch pipe sizes only)

The outlet diameters as listed are in accordance with BS4825. The ASME specification, however, requires these diameters to be 0.005" (0.125mm) less in each case. An Outlet Diameter tolerance of +0.000 -0.005" has therefore been applied, so that the same fitting satisfies the requirements of both specification.

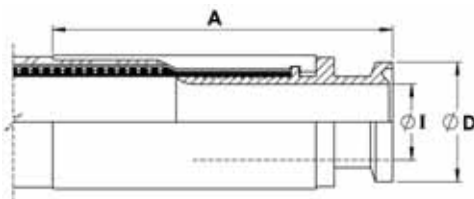

MINI-SANITARY TRICLAMP (TRICLOVER) FITTINGS

Nominal Hose Size	Nominal Pipe Size	Fitting Length A		Flange Dia. D		*Outlet Dia. I	
		in	mm	in	mm	in	mm
1/2"	1/2" & DN10	2.05	51	0.984	25.0	3/8	9.5
1/2"	3/4"	2.05	51	0.984	25.0	5/8	16.0
3/4"	3/4"	2.52	64	0.984	25.0	5/8	16.0

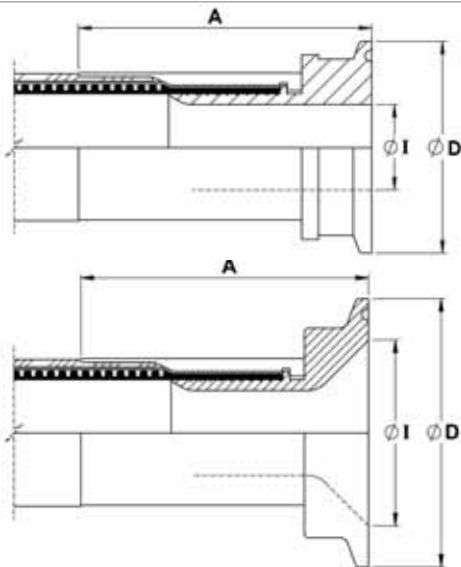

SANITARY TRICLAMP (TRICLOVER) FITTINGS

Nominal Hose Size	Nominal Pipe Size	Fitting Length A		Flange Dia. D		*Outlet Dia. I	
		in	mm	in	mm	in	mm
1/2"	1"	1.89	48	1.984	50.5	7/8	22.2
3/4"	DN15	2.44	62	1.156	34.0	5/8	16.0
1"	1"	2.64	67	1.984	50.5	7/8	22.2
1"	DN25	2.64	67	1.984	50.5	1	26.0
1"	1 1/2"	2.64	67	1.984	50.5	1 3/8"	34.9
*1 1/2"	1 1/2"	3.50	89	1.984	50.5	1 3/8"	34.9
*1 1/2"	DN40	3.50	89	1.984	50.5	1 1/2"	38.0
*2"	2"	3.62	92	2.516	64.0	1 7/8"	47.6
*2	DN50	3.62	92	2.516	64.0	1.975	50.0
*2"	2 1/2"	3.50	89	3.047	77.5	2 3/8"	60.3
*2"	DN65	3.50	89	3.047	77.5	2.600	66.0
*2"	3"	3.90	99	3.579	91.0	2 7/8"	73.0
*2"	DN80	3.90	99	4.176	106.0	3.191	81.0

\*These sizes are not available in Pharmalex Hose.

# PHARMALINE & PHARMALEX 90° ELBOW SANITARY TRICLAMP (TRICLOVER) FITTINGS

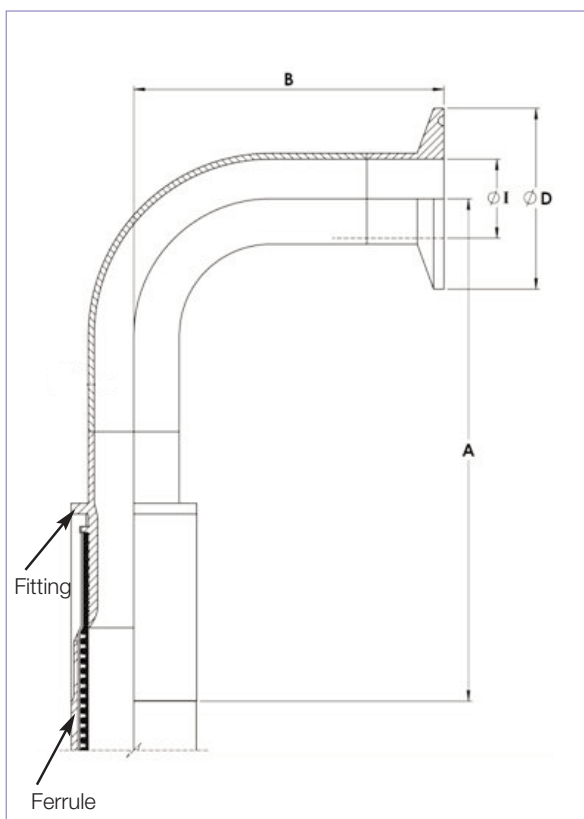

## ■ End Fitting Specification

- Generally in accordance with BS4825:Pt 3 and ASME BPE-a-2007

## ■ End Fitting Materials

- Fittings in Grade AISI 316L = EN 1.4404 = BS 316 S11
- Internal Bore average 15µin Ra, Electropolished if required
- Ferrules, in Grade 304 SS

## ■ Temperature and Pressure Ratings

For Standard Clamp and Standard (EPDM) Gasket

- Pressures up to 230 psi (16 Bar)
- Temperatures up to 250°F (120°C)
- Higher Pressures and Temperatures with Special Clamps and Gaskets

## ■ \*Outlet Diameters

The outlet diameters as listed are in accordance with BS4825. The ASME specification, however, requires these diameters to be 0.005" (0.125mm) less in each case. An Outlet Diameter tolerance of +0.000 -0.005" has therefore been applied, so that the same fitting satisfies requirements of both specifications.

Nominal Hose Size		Centre Line To Fitting End A		Centre Line to Face B		Flange Diameter D		*Outlet Diameter I	
in	mm	in	mm	mm	mm	in	mm	in	mm
1/2	13	5.78	147	1.60	41.0	0.984	25.0	3/8	9.5
3/4	20	6.41	163	1.60	41.0	0.984	25.0	5/8	16.0
1	25	6.26	159	2.00	51.0	1.984	50.5	7/8	22.2
*1 1/2	40	7.99	203	2.75	70.0	1.984	50.5	1 3/8	34.9
*2	50	9.33	237	3.50	88.9	2.16	64.0	1 7/8	47.6

\*These sizes are not available in Pharmalex Hose.

# PHARMALINE & PHARMALEX NPT and BSPT FIXED MALE AND NPT FIXED FEMALE FITTINGS

## ■ End Fitting Specification

NPT Taper Threads to American National Standard Pipe Taper Thread design to ANSI B2.1

BSPT Threads to British Standard Pipe Taper Thread design to BS21

Alternatives - Parallel Threads, Metric Threads and Others.

## ■ End Fitting Materials

- Fittings in Grade 316L SS
- Ferrules, in Grade 304 SS

Alternatives - Fittings in Zinc Plated Carbon Steel

## ■ Temperature and Pressure Ratings

As for the relevant size of hose on Page 5.

### FIXED MALE NPT or BSPT

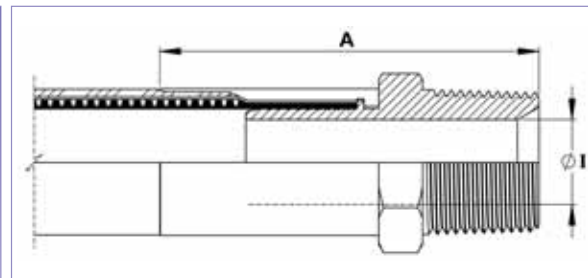

Nominal Hose Size		NPT or BSPT Thread Size	Fitting Length A		Fitting Inside Diameter I	
in	mm	in	in	mm	in	mm
1/2	13	1/2	2.50	63.5	0.38	9.53
3/4	20	3/4	3.15	80	0.63	15.88
1	25	1	3.46	88	0.80	20.24
*1 1/2	40	1 1/2	4.84	123	1.25	31.75
*2	50	2	5.16	131	1.75	44.45

### FIXED FEMALE NPT

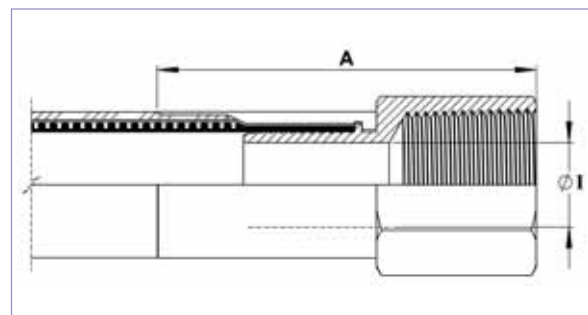

Nominal Hose Size		NPT Thread Size	Fitting Length A		Fitting Inside Diameter I	
in	mm	in	in	mm	in	mm
1/2	13	1/2	2.62	66.5	0.38	9.53
3/4	20	3/4	3.07	78	0.63	15.88
1	25	1	3.46	88	0.80	20.24
*1 1/2	40	1 1/2	4.45	113	1.25	31.75
*2	50	2	4.53	115	1.75	44.45

\*These sizes are not available in Pharmalex Hose.

# PHARMALINE & PHARMALEX 60° CONE SEAT FEMALE UNIONS and BSP FLAT SEAT LUG NUT FEMALE FITTING



## ■ End Fitting Specification

BSPP Threads to British Standard Pipe Parallel Thread design to BS21, 60° Cone Seat design, or Flat Seat.

Alternatives - Cone Seat Female Union Fittings can be supplied with a BSPP/BSPT Taper Male Adaptor if required.

## ■ Temperature and Pressure Ratings

As for the relevant size of hose on Page 5.

## ■ End Fitting Materials

- Spigots in Grade 316L SS
- Nuts in Grade 316L SS
- Ferrules, in Grade 304 SS

### Alternatives

- Cone Seat Female Unions can be supplied in Zinc Plated Carbon Steel if required.
- Lug Nuts can be supplied in Gun Metal (Bronze) if required.

## BSP 60° CONE SEAT FEMALE UNION FITTING

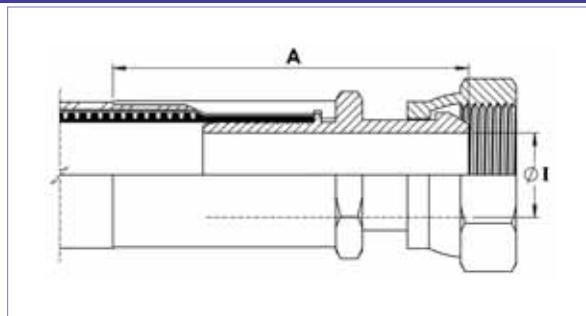

Nominal Hose Size		NPT or BSPT Thread Size		Fitting Length A		Fitting Inside Diameter I	
in	mm	in	mm	in	mm	in	mm
1/2	13	1/2	13	2.48	63	0.37	9.35
3/4	20	3/4	19	3.03	77	0.63	15.88
1	25	1	25	3.23	82	0.80	20.24
*1 1/2	40	1 1/2	38	4.29	109	1.25	31.75
*2	50	2	50	4.37	111	1.75	44.45

## BSP FLAT FACE LUG NUT FEMALE FITTING

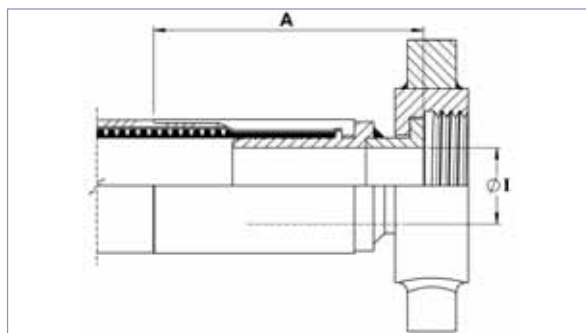

Nominal Hose Size		BSPP Thread Size		Fitting Length A		Fitting Bore Diameter I	
in	mm	in	mm	in	mm	in	mm
1	25	1	25	3.07	78	0.80	20.24
*1 1/2	40	1 1/2	38	3.31	84	1.25	31.75
*2	50	2	50	3.27	83	1.75	44.45

\*These sizes are not available in Pharmalex Hose.

# PHARMALINE & PHARMALEX 37° JIC FEMALE FITTINGS and UNIONS

## ■ End Fitting Specification

- SAE J514 37° Flare JIC Female Fitting
- 37° JIC Male-to-NPT Male/Female Adaptors
- NPT Threads to ANSI B2.1

## ■ Temperature and Pressure Ratings

Same Maximum Working Pressure and Temperature as for the relevant size of Hose, on page 5

## ■ End Fitting Materials

- Spigots in Grade 316
- Nuts in 316L SS
- Ferrules, in Grade 304 SS

Note - Not usable with SAE 45° Flare fittings which have the same thread.

Alternatives - Can be supplied in other materials, such as zinc plated carbon steel, Hastelloy, Monel etc.

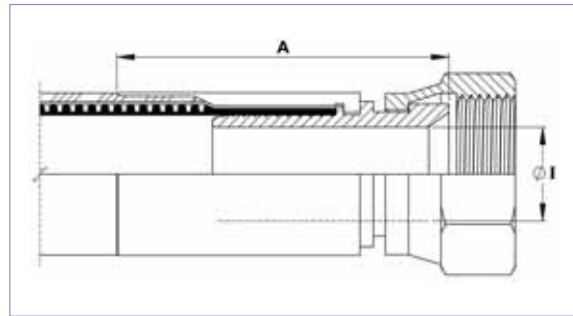

Nominal Hose Size		37° JIC Thread Size	Fitting Length A		Hex Size H		Fitting Inner Diameter I	
in	mm	in	in	mm	in	mm	in	mm
1/2	13	3/4 -16	1.95	49.5	0.88	22.2	0.38	9.5
3/4	20	1 1/16 -12	2.48	63	1.25	31.7	0.63	15.9
1	25	1 5/16 -12	2.60	66	1.50	38.1	0.80	20.2
*1 1/2	40	1 7/8 -12	3.66	93	2.25	57.1	1.25	31.7
*2	50	2 1/2 -12	3.90	99	2.88	73.0	1.75	44.4

\*These sizes are not available in Pharmalex Hose.

## JIC TO NPT MALE UNION (Including a JIC MALE-TO-NPT MALE ADAPTOR)

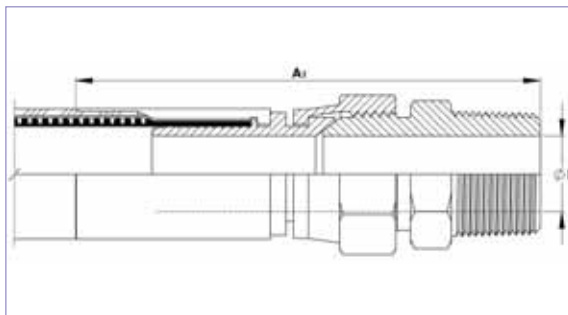

## JIC TO NPT FEMALE UNION (Including a JIC MALE-TO-NPT FEMALE ADAPTOR)

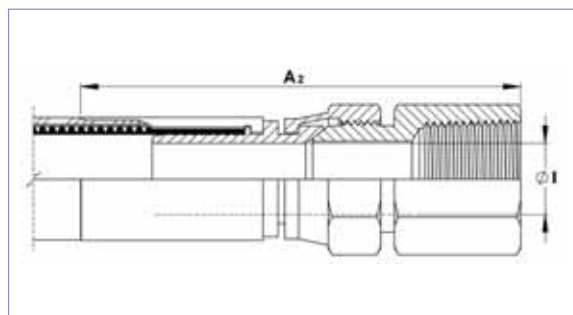

Nominal Hose Size		Male Union Length A1		Female Union Length A2		Fitting Inner Diameter I	
in	mm	in	mm	in	mm	in	mm
1/2	13	3.33	84.5	3.44	87.5	0.38	9.5
3/4	20	4.33	110	4.21	107	0.63	15.9
1	25	4.80	122	4.49	114	0.80	20.2

# PHARMALINE & PHARMALEX TUBE ADAPTOR (GROOVED STANDPIPE) FITTINGS



## ■ Specifications

- Compatible with existing Industrial Standard Tube Fitting Components.

## ■ Temperature and Pressure Ratings

As for the relevant size of hose on Page 5.

## ■ End Fitting Materials

- Fitting in Grade 316L SS  
- Ferrules, in Grade 304 SS

Alternatives -Can be supplied with matching Female Nuts & Ferrules (clamping Ferrules) to suit.

## NON LINED TUBE ADAPTOR (GROOVED STANDPIPE) FITTING

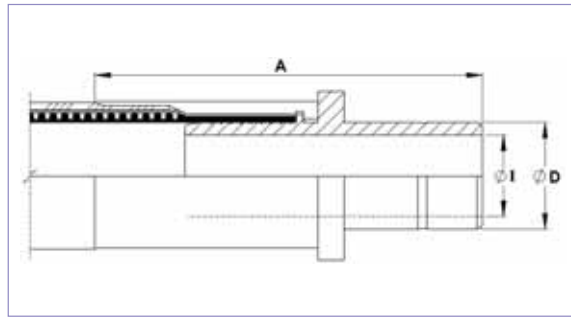

Nominal Hose Size		Fitting Length A		Diameter D		Fitting Inside Diameter I	
in	mm	in	mm	in	mm	in	mm
3/4	20	3.10	79	0.75	19.05	0.625	15.88
1	25	3.50	89	1.00	25.40	0.820	20.74

# PHARMALINE & PHARMALEX DIP PIPES

## FIXED DIP PIPES

### Description

Fixed Dip Pipes are fairly rigid, thick wall PTFE tubes, either straight or 90° elbowed, which are directly crimped to the end of Pharmaline and Pharmalex hoses. They are designed for insertion into drums, tanks and reaction vessels in order to suction drain (or inject) process fluids transferred through the hose.

### Materials

Standard dip pipes are in anti-static (AS) PTFE.

### How to order

Specify the size and material of the dip pipe, whether it is straight or 90° elbowed. Give the length of the find leg of the dip pipe and the length of the rest of the hose assembly separately.

### Maximum Working Pressures

Dip Pipes are normally only tested to 4 Bar Pressure, and are not suitable for use at pressures higher than 3 Bar. They are usable at negative pressure up to full vacuum.

If higher pressure ratings are required, consult Aflex Hose.

### Lengths

Dip Pipes are supplied as standard in 1 metre lengths, but can be supplied in any length to individual requirements.



Nominal Hose Bore Size		Approximate Dip Pipe Dimensions			
		Outside Diameter D		Inside Diameter I	
in	mm	in	mm	in	mm
3/4	20	0.87	22	0.51	13
1	25	1.14	29	0.83	21
1 1/2	40	1.54	39	1.00	27
2	50	2.17	55	1.58	40

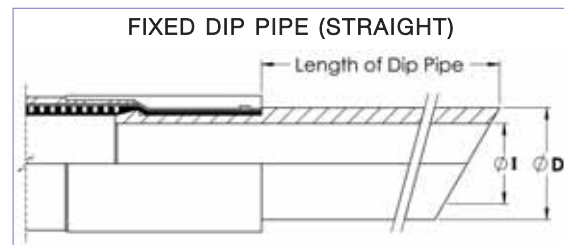

## DETACHABLE DIP PIPES

### Description

As Fixed Dip Pipes above, but connected to the hose through an end fitting, not by crimping direct to the hose.

### Design

A straight, or 90° elbowed anti-static PTFE Dip Pipe, fitted with a Flange or Cam & Groove Male PTFE Lined & Flared end fitting.

The most usual end fitting is a Cam Male (as shown), so the dip pipe can then be connected to a hose with a Cam Female end fitting.

### Specifications

As above for Fixed Dip Pipes.

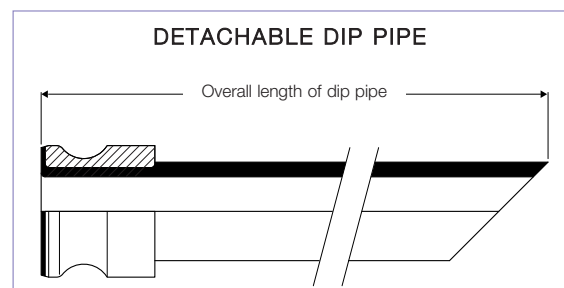

# PHARMALINE & PHARMALEX STANDARD and PURETAG LABELLING and COLOUR CODING SYSTEMS



## STANDARD LABELLING

All Pharmaline and Pharmalex hose assemblies are labelled with the following information:

- Manufacturers Name (Aflex Hose)
- Hose Size and Grade
- Max. Working Pressure
- Unique Serial Number
- Month & Year of Manufacture
- Aflex Hose Telephone Number
- CE Mark (if applicable)

This information is normally etched on to a loose stainless steel Ring mounted on the hose.

In some cases, at the discretion of Aflex Hose, the information may be etched on to a thin stainless steel plate which is clamped to the hose, or on to the end fitting ferrule at one end. This may be necessary for example, if the customer requires additional information which may not fit on to a Ring.

Customers may specify which labelling system they require, and may request additional information on the label.



## PURETAG LABELLING AND COLOUR CODING

### Puretag Labelling and Colour Coding (Patent Pending)

A label and/or Colour Code is encapsulated on to the braid by a transparent platinum cured silicone rubber cover which is integrally vulcanised and fully bonded to the rubber cover on the hose. The label is replaceable if required.

Another alternative is an RFID programmable tag, encapsulated in the Rubber (Aflex Hose "Flowtag" system) - consult Aflex Hose for details.

Further information is available on the Puretag product information document on the website.



## SPIRAL STRIP COLOUR CODING

### Colour Coding

A coloured PTFE spiral strip is wound on to the hose.

It can be left loose, or it can be encapsulated under a transparent, heat-shrunk polyolefin sleeve.

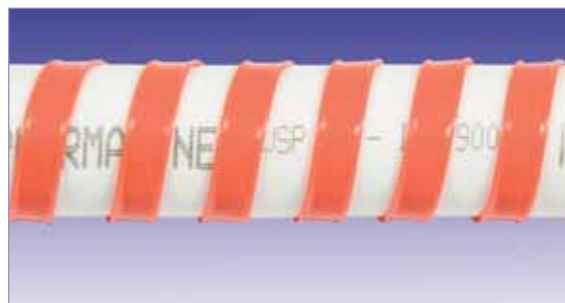

# HOSE CONFIGURATION & LENGTH CALCULATIONS

## - for BEND RADIUS

### Hose Configuration Requirements

Hose Assemblies are usually connected at both ends in service. They may then either remain in a fixed, or static configuration or in a flexing, or dynamic configuration.

Whether static or dynamic, the First Rule concerning the configuration of the hose is that the bend radius of the hose must never be less than the Minimum Bend Radius (MBR) for the hose as listed in the relevant hose brochure.

The most common situation when this is likely to occur is when the hose is flexed at the end fitting, with stress being applied to the hose at an angle to the axis of the end fitting. Typically, this happens either because the length of the hose is too short, or because the weight of the hose plus contents creates a stress at an angle to the end fitting.

The Second Rule, therefore, if possible, is to design the configuration to ensure that any flexing in the hose takes place away from the end fittings.

### (Dynamic) Configuration

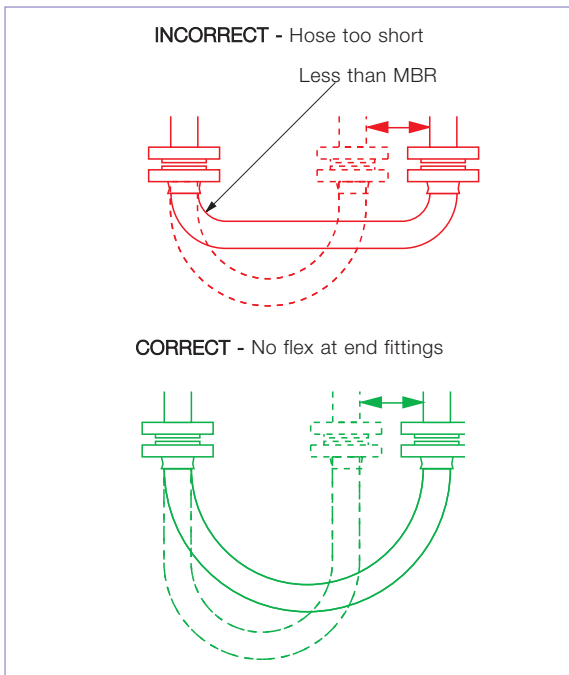

### (Static) Configuration

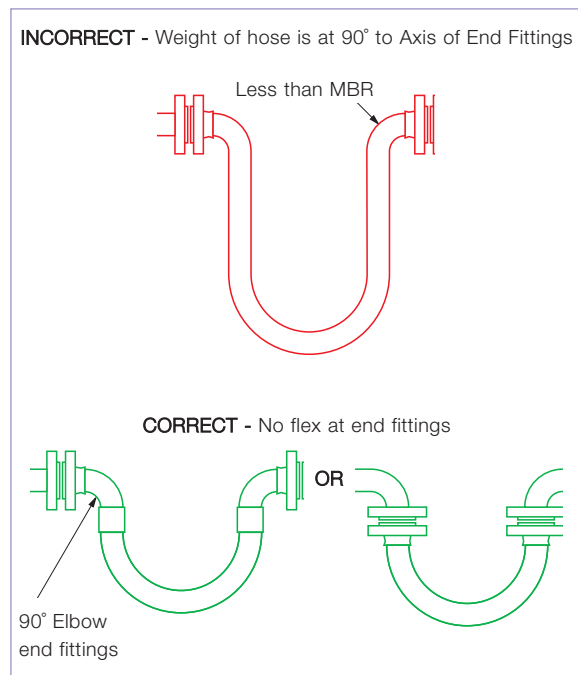

# HOSE CONFIGURATION & LENGTH CALCULATIONS

## - for ABRASION & TORQUE



The Third Rule is that the hose configuration should always be designed, and supported where necessary, to avoid any possibility of external abrasion.

In some cases, the length, configuration and angle of the hose can be designed to avoid abrasion. In others, static or moving support frames or support wheels are required.

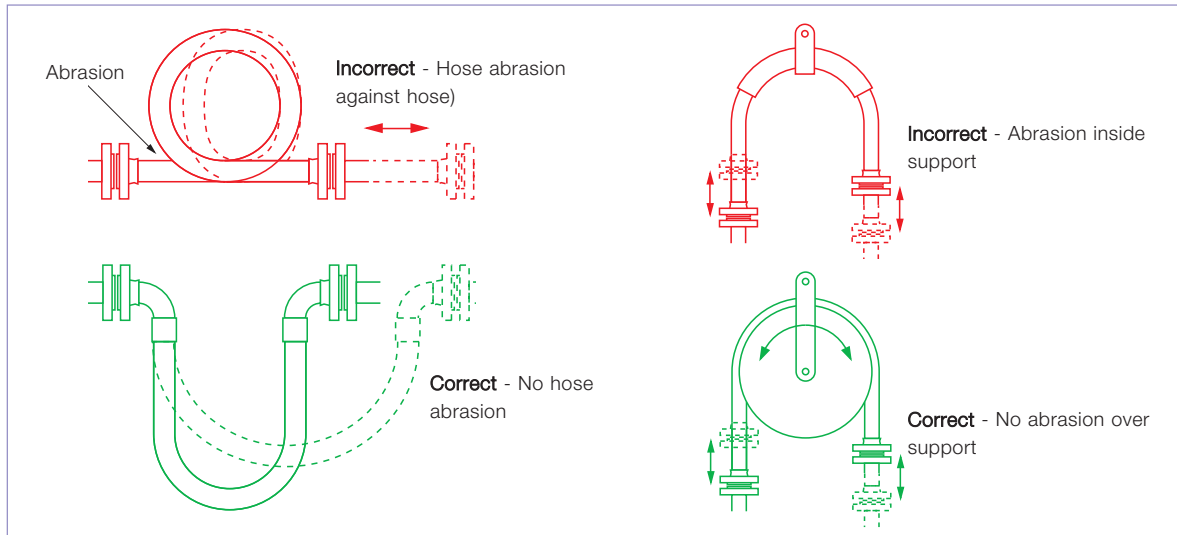

The Fourth Rule is that the hose must not be subjected to torque, either during connection, or as a result of the flexing cycle.

Torque (twist) in the hose can be applied during connection if the hose is accidentally twisted, or if the second end being connected is a screwed connection, and the hose is subjected to torque during final tightening.

In a flexing application, if any flexing cycle of the hose occurs in 3 dimensions instead of 2, then torque will also occur:

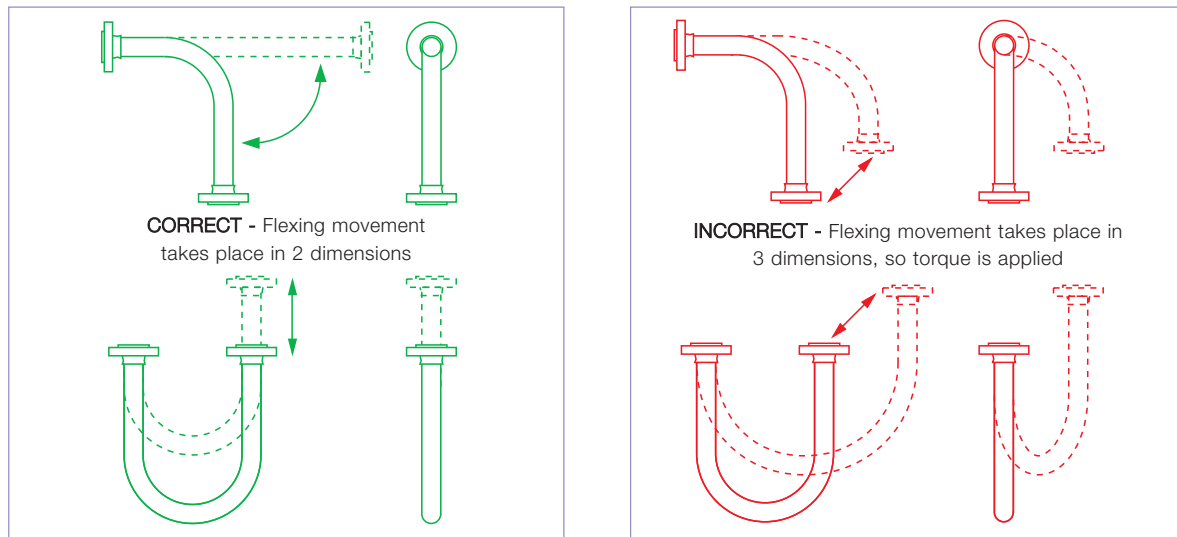

Both Pharmaline and Pharmalex hose have good resistance to a small level of torque, much better resistance than rubber or SS hose types, but it is still the best practice to take whatever steps are necessary to eliminate torque. If in doubt, consult Aflex Hose.

# HOSE CONFIGURATION & LENGTH CALCULATIONS

## - for LENGTH CALCULATIONS

### Calculating The Hose Length

The formula for calculating the bent section of the hose length around a radius is derived from the basic formula that the circumference of a circle =  $2\pi R$ , where  $R$  = the radius of the circle, and  $\pi$  = a constant, = 3.142.

So, if the hose goes around a 90° bend, which is  $\frac{1}{4}$  of a full circumference, and the radius of the bend is  $R$ , then the length of the hose around the bend is  $= \frac{1}{4} \times 2\pi R$ . Or half way round, in a U-shape,  $= \frac{1}{2} \times 2\pi R$ .

#### Note :

In calculating the length of a hose assembly, the (non-flexible) length of the end fittings must be added in, also the length of any straight sections of hose, as in the following example:

#### Example :

To calculate the length for a 2" bore size hose with flange end fittings, to be fitted in a 90° configuration with one leg 400mm long, the other 600mm long.

$$\begin{aligned} \text{Length of Bent Section (yellow)} &= \frac{1}{4} \times 2\pi R \quad (334) \\ &= \frac{1}{4} \times 2 \times 3.142 \times 334 = \mathbf{525\text{mm}} \\ \text{Length of top, Straight Section, including the top end fitting length} &= 600 - 334 = \mathbf{266\text{mm}} \\ \text{Length of bottom end fitting} &= \mathbf{66\text{mm}} \\ \text{Total length of Hose Assembly} &= 525 + 266 + 66 = \mathbf{857\text{mm}} \end{aligned}$$

#### Things to consider

- A hose will normally take the longest radius available to it to go around a corner, not the MBR! Also - always remember to include the **non-flexible** end fitting lengths.
- In dynamic applications, remember to always calculate the lengths for the most extended configuration during the flexing cycle, not the least extended.
- If the configuration is simply too complex for calculation, then obtain a length of flexible tubing of some kind, mark on paper, or a wall, or floor, or both where the connection points will be relative to each other, scaled down if necessary, then manually run the flexible tubing between them with full radii round bends. Measure the extended length, then scale up if necessary to determine the approximate length of the hose.

If in doubt, consult Aflex Hose.

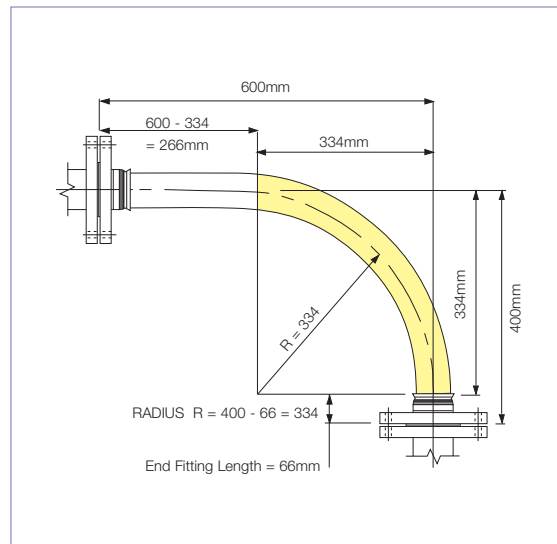
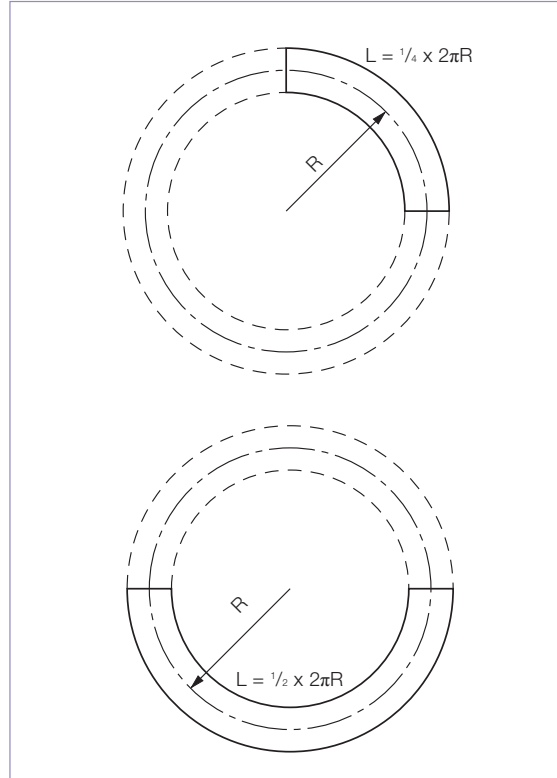

# CONDITIONS OF SALE

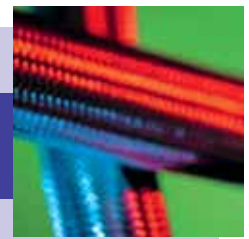

## General

Aflex PTFE hose products have not been designed or tested to be suitable for use in any **Aerospace, Medical Implantation** or **Radioactive** applications, nor is it suitable for use in any **USA military vehicles, weapons** or **equipment** and such use is therefore strictly prohibited unless written approval from Aflex Hose Ltd has been given.

Aflex Hose Ltd will not accept liability for any failures of the Aflex Hose Products which are caused by customers failing to perform their Responsibilities as specified in these Conditions of Sale.

It is the customer's strict Responsibility to review all of the usage limitations given for the hose which he intends to use in an application, to ensure that the application conditions are in compliance with those usage limitations. The usage limitations are specified both on this page, and throughout the relevant sections under "Products and Information" on the Aflex Hose website. Customers must always consult the latest, up to date information, which is available and downloadable from the Aflex website, or request from Aflex Hose Ltd.

It must be accepted, however, that the usage limitations specified elsewhere in the Hose Product Information and on this page are intended as a guide only, since every possible factor in every type of application cannot possibly be covered. It is therefore the Customer's Responsibility to ensure the design suitability and safety of the products in their intended applications, giving particular consideration to the chemical and electrostatic compatibility of the fluids or gases passing through, the possibility of diffusion of fluid or gases through the PTFE hose lining, the possibility of external corrosive conditions, the types and likelihood of excessive mechanical abuse, such as abrasion (internal or external), crushing, excessive flexing or vibrations etc, and any excessive temperature and/or pressure "pulsing" conditions, all of which may cause premature hose failure. It is also the Customer's Responsibility to consider, and take account of the degree of risk involved in any hose failure, including the provision of adequate protection in the event of any risk to employees or the general public. In applications where any type of hose failure would lead to financial losses if the hose is not replaced immediately, it is the Customer's Responsibility to order and hold in stock spare hose(s) accordingly. It is also the Customer's Responsibility to advise Aflex Hose in writing if there are any special requirements for the hose, including cleaning, or drying, or extra testing requirements which are in addition to normal industrial standards.

If the Customer has any doubts concerning these or any other usage limitation or safety parameters, it is the Customer's Responsibility to consult Aflex Hose Ltd, to request a written response to any queries.

It is the Responsibility of the Customer to ensure that if the product is sold on, or passed on, however many times, that all the necessary information including this page and the Aflex Hose website address are also passed on to the final user, together with a specific requirement that the final user must review the usage limitations in terms of his own application.

## Hose Service Life

It is not possible to guarantee a minimum service life for any of the Aflex Hose products which can be applicable for every type of application.

(For example, PTFE lined hose has been used in one application where it was cycled with hot steam, then cold water, also flexed every 17 seconds 24 hours per day, and the customer was very satisfied with a service life of 3 weeks before failure. In other light duty applications carrying pharmaceutical products, however, many Corroflon hoses are still performing satisfactorily after 20 years in service).

Service life predictions or guarantees can only be given in cases where all the relevant information concerning the application is given in writing to Aflex Hose, and Aflex Hose subsequently replies in writing prior to the order being placed.

If such a written undertaking is not sought and given, then Aflex Hose cannot be held liable for any hose product failure which the customer considers to be premature, excepting failures which are due to faulty materials or manufacturing defects.

## 24 Month Warranty

Aflex Hose Ltd warrants its products to be free from faulty materials or manufacturing defects from the date of the initial sale, for 24 months.

## Product Failure

In the event of a product failure, Aflex Hose requests that the product should not be cut up or tampered with, but should be de-contaminated and returned to Aflex Hose, plus a decontamination certificate, for examination and analysis of the fault. The customer should also provide full details in writing of the application conditions under which the hose failed, including Pressure, Vacuum, Temperature, Flexing and any cycling of any of these, also the fluid and gases passing through the hose, and the total time that the hose has been in service. The customer may send his own witness to the examination if required. Aflex Hose will provide a full Non Conformance Report for the customer.

If faulty materials or a manufacturing defect in the hose was responsible for the failure to perform then, the maximum liability to be accepted by Aflex Hose would include the invoice value of the failed hose itself, or the invoice value of the whole customer order if appropriate, also any reasonable costs for removal and replacement of the hose, and costs for packing and despatching the failed hose back to Aflex Hose. Aflex Hose Ltd will not accept liability for any other consequential or financial losses, including, but not limited to loss of profits, loss of products or downtime costs.

## Untested Hose for Self Assembly by Customers

Aflex Hose sometimes supplies "loose" hose, without end fittings attached to Self Assembly Customers, who will then cut the hose to length and attach end fittings to make up Hose Assemblies.

Self Assembly Customers must then accept the responsibility to carry out pressure testing of 100% of such assemblies to 1½ times the Maximum Working Pressure before supply for end use, to validate both the hose and the end fitting attachment.

When pressure testing hoses with a plastic or rubber outer cover, the cover will mask any signs of leakage for a time. It is therefore recommended that pressure testing with air under water for a minimum test period of 5 minutes should be applied to covered hoses.

Unless the customer requests, and Aflex Hose confirm that their loose hose is pressure tested before supply, such testing is not normally applied by Aflex Hose, because this testing requirement is satisfied by the Self Assembly Customer during his own testing of the finished Hose Assembly.

The Self Assembly Customer must also accept responsibility for determining and approving the Design Suitability of the hose assemblies for their intended use before supply.

This includes determining and requesting or applying any special tests which may be identified as necessary to ensure suitability for the intended use.

Aflex Hose will only accept liability for its hose products which are assembled by customers themselves if all the hose and fitting components were either supplied by Aflex Hose or manufactured in accordance with Aflex Hose drawings, and they were assembled and tested in accordance with Aflex Hose's current Manufacturing and Testing Instructions.

## Untested Hose Assemblies

Aflex Hose is sometimes requested by customers to attach non-standard end fittings to hose assemblies which they supply, and in some cases it is not possible to connect these fittings to the pressure test system. In such cases a Concession not to test is obtained from the Customer, and a label is attached to the hose assembly, warning that it requires pressure testing before use.

## Force Majeure

Aflex Hose Ltd shall not be liable for any delay or default in performing in accordance with any Customers' order if the delay or default is caused by conditions beyond its control, including, but not limited to wars, insurrections, strikes, natural disasters or performance failures by Carriers, sub-contractors or other third parties outside the control of Aflex Hose Ltd.

## Legal System

These Conditions of Sale are subject to English Law.

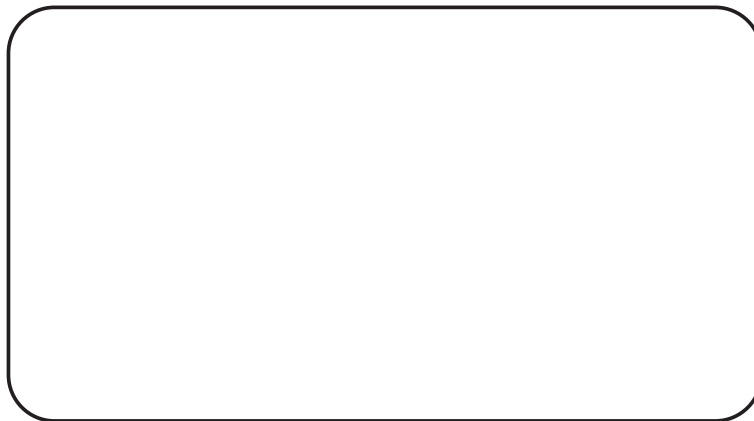

**Aflex Hose Ltd**  
World's Leading Manufacturer of PTFE Flexible Hose

**AFLEX HOSE LTD**  
Spring Bank Industrial Estate, Watson Mill Lane,  
Sowerby Bridge, Halifax, West Yorkshire HX6 3BW

T: +44 (0)1422 317200 F: +44 (0)1422 836000  
W: [www.aflex-hose.com](http://www.aflex-hose.com)



**Aflex Hose USA, LLC**  
World's Leading Manufacturer of PTFE Flexible Hose

**AFLEX HOSE USA, LLC**  
6111 Keller's Church Road, Unit B  
Pipersville, Pennsylvania, PA18947

T: 215 766 1455 F: 215 766 1688  
W: [www.aflex-hose.com](http://www.aflex-hose.com)



Certificate No. 1977

USA PHL&PHX/28.06.10/Rev. 6